



**Holtest ABSOLUTE Borematic**



**Inside Micrometers**



**Bore Gages**

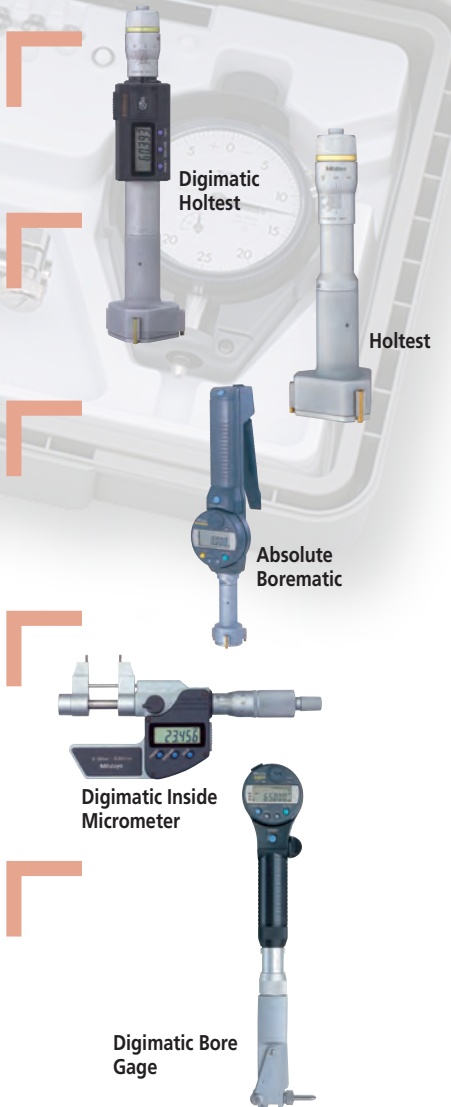

Digimatic Holtest

Holtest

Absolute Borematic

Digimatic Inside Micrometer

Digimatic Bore Gage

### INDEX

<b>Holtest</b>	
Digimatic Holtest	C-2,3
Holtest	C-4,5
Holtest (Type II)	C-6,7
Borematic	C-8,9
Holtest/Digimatic Holtest/Borematic	C-10
<b>Inside Micrometers</b>	
Tubular Inside Micrometers	C-11,12
Inside Micrometers	C-13
Digimatic Tubular Inside Micrometers	C-14
Tubular Inside Micrometers	C-15-17
Inside Micrometers	C-18
Inside Micro Checker	C-19
<b>Bore Gages</b>	
Bore Gages	C-20-26
ABSOLUTE Digimatic Bore Gage	C-27
Bore Gages	C-28
Digimatic Chamfer Chek	C-29
Digimatic Hole Chek	C-29
Setting Rings	C-30,31
RM-120 Ring Master	C-32
Bore Gage Zero Checker	C-32
RM-120 Ring Master	C-32

# Digimatic Holtest

## SERIES 468 — Three-Point Internal Micrometers

### FEATURES

- TiN-coated measuring contact points provide excellent durability and impact resistance and allow the instrument to measure to the bottom of a blind hole (up to 100mm / 4" models).
- Large LCD readout.
- Functions available: Presetting, Zero/ABS, Auto power On/Off, Data hold, Data output, Error alarm, Battery replacement alarm.
- With Ratchet Stop for constant force.
- Can measure deep holes by attaching an Extension rod (optional).
- Setting rings for origin point setting are optional.
- Supplied in fitted plastic case up to 100mm / 4" . Over 100mm / 4" supplied in wooden case.



468-261



468-263



468-274



TiN coated contact points  
(\*-10" suffix models only)

### DIMENSIONS AND MASS

Range	L	Mass (g)
6 - 8mm / .275 - .35"	59	400
8 - 10mm / .35 - .425"	59	400
10 - 12mm / .425 - .5"	59	400
12 - 16mm / .5 - .65"	84	430
16 - 20mm / .65 - .8"	84	430
20 - 25mm / .8 - 1"	93	500
25 - 30mm / 1 - 1.2"	93	510
30 - 40mm / 1.2 - 1.6"	103.8	510
40 - 50mm / 1.6 - 2"	103.8	530
50 - 63mm / 2 - 2.5"	105.4	650
62 - 75mm / 2.5 - 3.0"	105.4	660
75 - 88mm / 3.0 - 3.5"	105.4	990
87 - 100mm / 3.5 - 4.0"	105.4	1000
100 - 125mm / 4 - 5"	151.4	970
125 - 150mm / 5 - 6"	151.4	1060
150 - 175mm / 6 - 7"	151.4	1150
175 - 200mm / 7 - 8"	151.4	1240
200 - 225mm / 8 - 9"	151.4	1330
225 - 250mm / 9 - 10"	151.4	1420
250 - 275mm / 10 - 11"	151.4	1510
275 - 300mm / 11 - 12"	151.4	1600

Unit: mm

#### Measuring a Blind Hole

The measuring contact points held in the jaws permit measuring the diameter of a blind hole to the bottom.  
(up to 100mm / 4" models)

Range	a	b	c
6 - 12mm / .275 - .5"	2	—	2.5
12 - 20mm / .5 - .8"	0.3	5.6	3.5
20 - 30mm / .8 - 1.2"	0.3	8.3	5.2
30 - 50mm / 1.2 - 2"	0.3	13	10
50 - 100mm / 2 - 4"	0.3	17	14
100 - 300mm / 4 - 12"	12.4	21	13.8



### Technical Data

Accuracy: Refer to the list of specifications.  
 Resolution: 0.001mm or .00005"/0.001mm  
 (over 4 - 5" models: .0001"/0.001mm)  
 Contact point: TiN coating  
 Measuring method: Three-point method  
 Display: LCD  
 Battery: SR44 (2 pcs.), **938882**  
 Battery life: Approx. 8 months under normal use

### Function

Zero/ABS, Auto Power On/Off, Data hold, Data output,  
 Preset, inch/mm conversion (on inch/metric models only)  
 Alarm: Low voltage, Counting value composition error

### Optional Accessories

- 05CZA662:** SPC cable (1m / 40")
- 05CZA663:** SPC cable (2m / 80")
- 04AZB157:** Mounting plate for stand
- 156-101:** Stand
- 952322:** Extension rod 100mm / 3.94"  
For range 6-12mm / .275 - .5" models
- 952621:** Extension rod 150mm / 5.9"  
For range 12-20mm / .5" - .8" models
- 952622:** Extension rod 150mm / 5.9"  
For range 20-50mm / .8" - 2" models
- 952623:** Extension rod 150mm / 5.9"  
For range 50-300mm / 2" - 12" models



## SPECIFICATIONS

**Metric** Individual

Range	Order No.	Accuracy
6 - 8mm	<b>468-161</b>	±2µm
8 - 10mm	<b>468-162</b>	±2µm
10 - 12mm	<b>468-163</b>	±2µm
12 - 16mm	<b>468-164</b>	±2µm
16 - 20mm	<b>468-165</b>	±2µm
20 - 25mm	<b>468-166</b>	±3µm
25 - 30mm	<b>468-167</b>	±3µm
30 - 40mm	<b>468-168</b>	±3µm
40 - 50mm	<b>468-169</b>	±3µm
50 - 63mm	<b>468-170</b>	±3µm
62 - 75mm	<b>468-171</b>	±3µm
75 - 88mm	<b>468-172</b>	±3µm
87 - 100mm	<b>468-173</b>	±3µm
100 - 125mm	<b>468-174</b>	±5µm
125 - 150mm	<b>468-175</b>	±5µm
150 - 175mm	<b>468-176</b>	±5µm
175 - 200mm	<b>468-177</b>	±5µm
200 - 225mm	<b>468-178</b>	±5µm
225 - 250mm	<b>468-179</b>	±5µm
250 - 275mm	<b>468-180</b>	±5µm
275 - 300mm	<b>468-181</b>	±5µm

**Inch/Metric** Individual  with TiN coated contact points

Range	Order No.	Accuracy
.275 - .35" / 6.925 - 8.89mm	<b>468-261</b>	±.0001"
.35 - .425" / 8.89 - 10.795mm	<b>468-262</b>	±.0001"
.425 - .5" / 10.795 - 12.7mm	<b>468-263</b>	±.0001"
.5 - .65" / 12.7 - 16.51mm	<b>468-264</b>	±.0001"
.65 - .8" / 16.51 - 20.32mm	<b>468-265</b>	±.0001"
.8 - 1" / 20.32 - 25.4mm	<b>468-266</b>	±.00015"
1 - 1.2" / 25.4 - 30.48mm	<b>468-267</b>	±.00015"
1.2 - 1.6" / 30.48 - 40.64mm	<b>468-268</b>	±.00015"
1.6 - 2" / 40.64 - 50.8mm	<b>468-269</b>	±.00015"
2 - 2.5" / 50.8 - 63.5mm	<b>468-270</b>	±.00015"
2.5 - 3" / 63.5 - 76.2mm	<b>468-271</b>	±.00015"
3 - 3.5" / 76.2 - 88.9mm	<b>468-272</b>	±.00015"
3.5 - 4" / 88.9 - 101.6mm	<b>468-273</b>	±.00015"
4 - 5" / 101.6 - 127mm	<b>468-274</b>	±.00025"
5 - 6" / 127 - 152.4mm	<b>468-275</b>	±.00025"
6 - 7" / 152.4 - 177.8mm	<b>468-276</b>	±.00025"
7 - 8" / 177.8 - 203.2mm	<b>468-277</b>	±.00025"
8 - 9" / 203.2 - 228.6mm	<b>468-278</b>	±.00025"
9 - 10" / 228.6 - 254mm	<b>468-279</b>	±.00025"
10 - 11" / 254 - 279.4mm	<b>468-280</b>	±.00025"
11 - 12" / 279.4 - 304.8mm	<b>468-281</b>	±.00025"



468-986

### Complete Unit Set

Each set includes complete gages (display units and measuring heads for each size).

**Metric**

with TiN coated contact points

Range	Order No.	Individual range	Setting rings included	Remarks
6 - 12mm	<b>468-981</b>	6-8, 8-10, 10-12mm	ø8mm, ø10mm	—
12 - 25mm	<b>468-982</b>	12-16, 16-20, 20-25mm	ø16mm, ø20mm	—
25 - 50mm	<b>468-983</b>	25-30, 30-40, 40-50mm	ø30mm, ø40mm	—
50 - 75mm	<b>468-984</b>	50-63, 62-75mm	ø62mm	—
75 - 100mm	<b>468-985</b>	75-88, 87-100mm	ø87mm	—

**Inch/Metric**

with TiN coated contact points

Range	Order No.	Individual range	Setting rings included	Remarks
.275 - .5" / 6.925 - 12.7mm	<b>468-986</b>	.275-.35", .35-.425", .425-.5"	.35" DIA., .425" DIA.	—
.5 - 1" / 12.7 - 25.4mm	<b>468-987</b>	.5-.65", .65-.8", .8-1"	.65" DIA., .8" DIA.	—
1 - 2" / 25.4 - 50.8mm	<b>468-988</b>	1-1.2", 1.2-1.6", 1.6-2"	1.2" DIA., 1.6" DIA.	—
2 - 3" / 50.8 - 76.2mm	<b>468-989</b>	2-2.5", 2.5-3"	2.5" DIA.	—
3 - 4" / 76.2 - 101.6mm	<b>468-990</b>	3-3.5", 3.5-4"	3.5" DIA.	—



468-978

### Interchangeable Head Set

Each set includes one display unit with interchangeable measuring heads of the sizes specified.

**Metric**

with TiN coated contact points

Range	Order No.	Individual range	Setting rings included	Remarks
6 - 12mm	<b>468-971</b>	6-8, 8-10, 10-12mm	ø8mm, ø10mm	with extension rod
12 - 20mm	<b>468-972</b>	12-16, 16-20mm	ø16mm.	with extension rod
20 - 50mm	<b>468-973</b>	20-25, 25-30, 30-40, 40-50mm	ø25mm, ø40mm	with extension rod
50 - 100mm	<b>468-974</b>	50-63, 62-75, 75-88, 87-100mm	ø62mm, ø87mm	with extension rod
100 - 200mm	<b>468-975</b>	100-125, 125-150, 150-175, 175-200mm	ø125mm, ø175mm	with extension rod

**Inch/Metric**

with TiN coated contact points

Range	Order No.	Individual range	Setting rings included	Remarks
.275 - .5" / 6.925 - 12.7mm	<b>468-976</b>	.275-.35", .35-.425", .425-.5"	.35" DIA., .425" DIA.	with extension rod
.5 - .8" / 12.7 - 20.32mm	<b>468-977</b>	.5-.65", .65-.8"	.65" DIA.	with extension rod
.8 - 2" / 20.32 - 50.8mm	<b>468-978</b>	.8-1", 1-1.2", 1.2-1.6", 1.6-2"	1" DIA., 1.6" DIA.	with extension rod
2 - 4" / 50.8 - 101.6mm	<b>468-979</b>	2-2.5", 2.5-3", 3-3.5", 3.5-4"	2.5" DIA., 3.5" DIA.	with extension rod
4 - 8" / 101.6 - 203.2mm	<b>468-980</b>	4-5", 5-6", 6-7", 7-8"	5" DIA., 7" DIA.	with extension rod

**Mitutoyo**

# Holtest

## SERIES 368 — Three-Point/Two-Point Internal Micrometers

These Holtests are versatile, self-centering three-point internal micrometers for the accurate and efficient direct-measurement of internal diameters. Three anvils, evenly spaced at 120° apart, contact the internal wall surfaces and find true alignment with the axis of the bore for accurate ID measurement.



368-268

368-174

### FEATURES

- TiN-coated measuring contact points (over 6mm / .275" range models) provide excellent durability and impact resistance and allow the instrument to measure to the bottom of a blind hole (up to 100mm / 4" models).
- Highly durable because of carbide-tipped contact points (anvils up to 12mm / .5" models).
- Can measure deep holes using an Extension rod (optional) which is available on models over 6mm (.275") measuring range.
- With Ratchet Stop for constant force.
- Setting Rings for zero point adjustment are optional.
- Supplied in fitted plastic case up to 100mm / 4". Over 100mm / 4" supplied in wooden case.



368-001

Two-point contact type



TiN coated contact points (excluding models up to 12mm/.5")

### DIMENSIONS

#### Measuring a Blind Hole

The measuring contact points held in the jaws permit measuring the diameter of a blind hole right down to the bottom (up to 100mm / 4" models).

Unit: mm

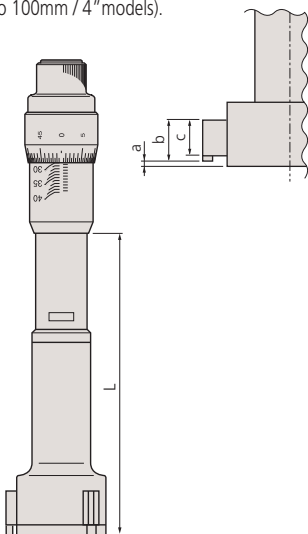

Range	L	Mass (g)	Range	L	Mass (g)
2 - 2.5mm / .08 - .1"	12	88	40 - 50mm / 1.6 - 2"	102	330
2.5 - 3mm / .1 - .12"	12	88	50 - 63mm / 2 - 2.5"	105	440
3 - 4mm / .12 - .16"	22	91	62 - 75mm / 2.5 - 3"	105	450
4 - 5mm / .16 - .2"	22	91	75 - 88mm / 3 - 3.5"	105	490
5 - 6mm / .2 - .24"	22	91	87 - 100mm / 3.5 - 4"	105	500
6 - 8mm / .275 - .35"	59	57	100 - 125mm / 4 - 5"	161	1050
8 - 10mm / .35 - .425"	59	58	125 - 150mm / 5 - 6"	161	1120
10 - 12mm / .425 - .5"	59	59	150 - 175mm / 6 - 7"	161	1190
12 - 16mm / .5 - .65"	82	140	175 - 200mm / 7 - 8"	161	1260
16 - 20mm / .65 - .8"	82	145	200 - 225mm / 8 - 9"	161	1420
20 - 25mm / .8 - 1"	94	250	225 - 250mm / 9 - 10"	161	1580
25 - 30mm / 1 - 1.2"	94	270	250 - 275mm / 10 - 11"	161	1600
30 - 40mm / 1.2 - 1.6"	102	290	275 - 300mm / 11 - 12"	161	1690

Range	a	b	c
2 - 6mm / .08 - .275"	—	—	2
6 - 12mm / .275 - .5"	2	—	2.5
12 - 20mm / .5 - .8"	0.3	5.6	3.5
20 - 30mm / .8 - 1.2"	0.3	8.3	5.2
30 - 50mm / 1.2 - 2"	0.3	13	10
50 - 100mm / 2 - 4"	0.3	17	14
100 - 300mm / 4 - 12"	12.4	21	13.8



### Technical Data

Graduation: 0.001mm, 0.005mm\*, .0001" or .0002"\*  
(\*over 12mm or .5" models)

Range	Measuring method	Contact-point material
2-6mm/.08-.28"	Two-point method	Carbide
6-300mm/.275-12"	Three-point method	TiN coating (1700-2000HV)

### Optional Accessories

- 952322:** Extension rod 100mm / 3.94"  
For range 6-12mm / .275-.5" models
- 952621:** Extension rod 150mm / 5.9"  
For range 12-20mm / .5" - .8" models
- 952622:** Extension rod 150mm / 5.9"  
For range 20-50mm / .8" - 2" models
- 952623:** Extension rod 150mm / 5.9"  
For range 50-300mm / 2"-12" models

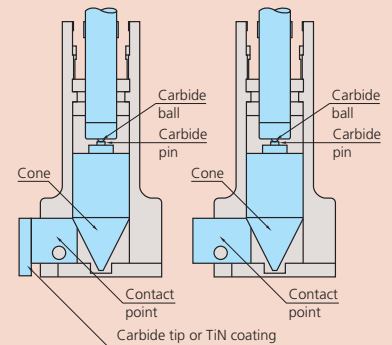

Using the optional extension rod

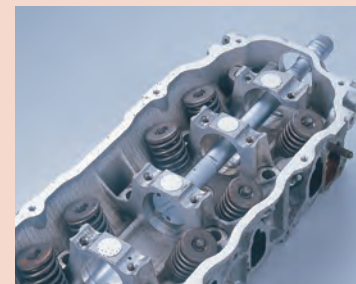



## SPECIFICATIONS

Metric Individual		
Range	Order No.	Accuracy
2 - 2.5mm	368-001	±2μm
2.5 - 3mm	368-002	±2μm
3 - 4mm	368-003	±2μm
4 - 5mm	368-004	±2μm
5 - 6mm	368-005	±2μm
6 - 8mm	368-161	±2μm
8 - 10mm	368-162	±2μm
10 - 12mm	368-163	±2μm
12 - 16mm	368-164	±2μm
16 - 20mm	368-165	±2μm
20 - 25mm	368-166	±3μm
25 - 30mm	368-167	±3μm
30 - 40mm	368-168	±3μm
40 - 50mm	368-169	±3μm
50 - 63mm	368-170	±3μm
62 - 75mm	368-171	±3μm
75 - 88mm	368-172	±3μm
87 - 100mm	368-173	±3μm
100 - 125mm	368-174	±5μm
125 - 150mm	368-175	±5μm
150 - 175mm	368-176	±5μm
175 - 200mm	368-177	±5μm
200 - 225mm	368-178	±5μm
225 - 250mm	368-179	±5μm
250 - 275mm	368-180	±5μm
275 - 300mm	368-181	±5μm

Inch Individual <input type="checkbox"/> with TiN coated contact points		
Range	Order No.	Accuracy
.08 - .1"	368-021	±.0001"
.1 - .12"	368-022	±.0001"
.12 - .16"	368-023	±.0001"
.16 - .2"	368-024	±.0001"
.2 - .24"	368-025	±.0001"
.24 - .28"	368-026	±.0001"
.275 - .35"	368-261	±.0001"
.35 - .425"	368-262	±.0001"
.425 - .5"	368-263	±.0001"
.5 - .65"	368-264	±.0001"
.65 - .8"	368-265	±.0001"
.8 - 1"	368-266	±.00015"
1 - 1.2"	368-267	±.00015"
1.2 - 1.6"	368-268	±.00015"
1.6 - 2"	368-269	±.00015"
2 - 2.5"	368-270	±.00015"
2.5 - 3"	368-271	±.00015"
3 - 3.5"	368-272	±.00015"
3.5 - 4"	368-273	±.00015"
4 - 5"	368-274	±.00025"
5 - 6"	368-275	±.00025"
6 - 7"	368-276	±.00025"
7 - 8"	368-277	±.00025"
8 - 9"	368-278	±.00025"
9 - 10"	368-279	±.00025"
10 - 11"	368-280	±.00025"
11 - 12"	368-281	±.00025"

### Complete Unit Set

Each set includes complete gages (micrometer head units and measuring heads for each size).

Metric Individual <input type="checkbox"/> with TiN coated contact points				
Range	Order No.	Individual range	Setting rings included	Remarks
2 - 3mm	368-906	2-2.5, 2.5-3mm	ø2.5mm	—
3 - 6mm	368-907	3-4, 4-5, 5-6mm	ø4mm, ø5mm	—
6 - 12mm	368-911	6-8, 8-10, 10-12mm	ø8mm, ø10mm	with extension rod
12 - 20mm	368-912	12-16, 16-20mm	ø16mm	with extension rod
20 - 50mm	368-913	20-25, 25-30, 30-40, 40-50mm	ø25mm, ø40mm	with extension rod
50 - 100mm	368-914	50-63, 62-75, 75-88, 87-100mm	ø62mm, ø87mm	with extension rod
100 - 200mm	368-915	100-125, 125-150, 150-175, 175-200mm	ø125mm, ø175mm	with extension rod

Inch Individual <input type="checkbox"/> with TiN coated contact points				
Range	Order No.	Individual range	Setting rings included	Remarks
.08" - .12"	368-926	.08-.1", .1-.12"	.1" DIA.	—
.12" - .28"	368-927	.12-.16", .16-.2", .2-.24", .24-.28"	.16" DIA., .24" DIA.	—
.275" - .5"	368-916	.275-.35", .35-.425", .425-.5"	.35" DIA., .5" DIA.	with extension rod
.5" - .8"	368-917	.5-.65", .65-.8"	.65" DIA.	with extension rod
.8" - 2"	368-918	.8-1", 1-1.2", 1.2-1.6", 1.6-2"	1" DIA., 1.6" DIA.	with extension rod
2" - 4"	368-919	2-2.5", 2.5-3", 3-3.5", 3.5-4"	2.5" DIA., 3.5" DIA.	with extension rod
4" - 8"	368-920	4-5", 5-6", 6-7", 7-8"	5" DIA., 7" DIA.	with extension rod

\*.0001" graduation



368-906



368-901-10

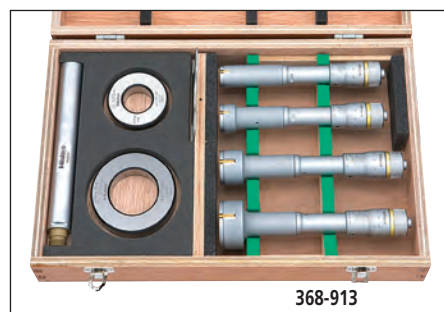

368-913

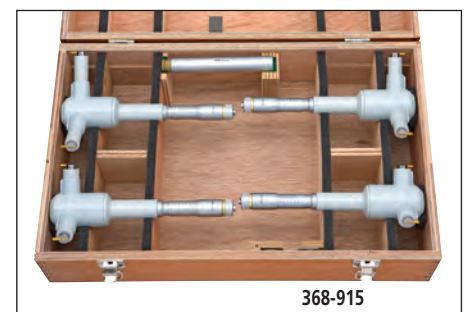

368-915

# Holtest (Type II)

## SERIES 368 — Three-Point Internal Micrometers

### FEATURES

- The Holtests (type II) have three contact points made of alloyed steel.
- Measurement can be taken closer to the bottom of the blind bore (up to 100mm / 4" models).
- Can measure deep holes using an Extension Rod (optional).
- With Ratchet Stop for constant force.
- Setting Rings for origin point settings are optional.
- Supplied in fitted plastic case up to 100mm / 4". Over 100mm / 4" supplied in wooden case.



368-869



368-770



368-774



### Technical Data

Graduation: 0.005mm or .0002"

Measuring method: Three-point method

Contact point: Hardening Steel (over HRC 60)

### Optional Accessories

**952621:** Extension rod 150mm / 5.9"  
For range 12-20mm / .5 - .8" models

**952622:** Extension rod 150mm / 5.9"  
For range 20-50mm / .8 - 2" models

**952623:** Extension rod 150mm / 5.9"  
For range 50-300mm / 2 - 12" models

### DIMENSIONS AND MASS

Range	L	Mass (g)
12 - 16mm / .5 - .65"	82	150
16 - 20mm / .65 - .8"	82	150
20 - 25mm / .8 - 1"	94	260
25 - 30mm / 1 - 1.2"	94	280
30 - 40mm / 1.2 - 1.6"	102	290
40 - 50mm / 1.6 - 2"	102	330
50 - 63mm / 2 - 2.5"	105	440
62 - 75mm / 2.5 - 3"	105	450
75 - 88mm / 3 - 3.5"	105	560
87 - 100mm / 3.5 - 4"	105	570
100 - 125mm / 4 - 5"	161	1020
125 - 150mm / 5 - 6"	161	1110
150 - 175mm / 6 - 7"	161	1200
175 - 200mm / 7 - 8"	161	1300
200 - 225mm / 8 - 9"	161	1420
225 - 250mm / 9 - 10"	161	1540
250 - 275mm / 10 - 11"	161	1690
275 - 300mm / 11 - 12"	161	1860

**Measuring a Blind Hole**

The measuring contact points held in the jaws permit measuring the diameter of a blind hole right down to the bottom (up to 100mm / 4" models).

Range	a	b
12 - 20mm / .5 - .8"	2.6	3.5
20 - 30mm / .8 - .12"	3.4	5.2
30 - 50mm / 1.2 - 2"	3.4	10
50 - 100mm / 2 - 4"	3.4	14
100 - 300mm / 4 - 12"	19.6	13.8

Unit: mm

## SPECIFICATIONS

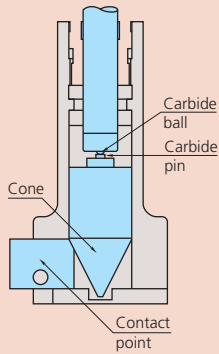

### HT (Type II)

Head Assy Order No.	Measuring Range	HT (type II) Order No.
04AZA839	12 - 16mm	368-764
04AZA840	16 - 20mm	368-765
04AZA848	20 - 25mm	368-766
04AZA849	25 - 30mm	368-767
04AZA857	30 - 40mm	368-768
04AZA858	40 - 50mm	368-769
04AZA870	50 - 63mm	368-770
04AZA871	62 - 75mm	368-771
04AZA872	75 - 88mm	368-772
04AZA873	87 - 100mm	368-773
04AZA895	100 - 125mm	368-774
04AZA896	125 - 150mm	368-775
04AZA897	150 - 175mm	368-776
04AZA898	175 - 200mm	368-777
04AZA899	200 - 225mm	368-778
04AZA900	225 - 250mm	368-779
04AZA901	250 - 275mm	368-780
04AZA902	275 - 300mm	368-781
04AZA841	.5 - .65"	368-864
04AZA842	.65 - .8"	368-865
04AZA850	.8 - 1"	368-866
04AZA851	1 - 1.2"	368-867
04AZA859	1.2 - 1.6"	368-868
04AZA860	1.6 - 2"	368-869
04AZA874	2 - 2.5"	368-870
04AZA875	2.5 - 3"	368-871
04AZA876	3 - 3.5"	368-872
04AZA877	3.5 - 4"	368-873
04AZA903	4 - 5"	368-874
04AZA904	5 - 6"	368-875
04AZA905	6 - 7"	368-876
04AZA906	7 - 8"	368-877
04AZA907	8 - 9"	368-878
04AZA908	9 - 10"	368-879
04AZA909	10 - 11"	368-880
04AZA910	11 - 12"	368-881

Metric Individual		
Range	Order No.	Accuracy
12 - 16mm	368-764	±2µm
16 - 20mm	368-765	±2µm
20 - 25mm	368-766	±3µm
25 - 30mm	368-767	±3µm
30 - 40mm	368-768	±3µm
40 - 50mm	368-769	±3µm
50 - 63mm	368-770	±3µm
62 - 75mm	368-771	±3µm
75 - 88mm	368-772	±3µm
87 - 100mm	368-773	±3µm
100 - 125mm	368-774	±5µm
125 - 150mm	368-775	±5µm
150 - 175mm	368-776	±5µm
175 - 200mm	368-777	±5µm
200 - 225mm	368-778	±5µm
225 - 250mm	368-779	±5µm
250 - 275mm	368-780	±5µm
275 - 300mm	368-781	±5µm

Inch Individual		
Range	Order No.	Accuracy
.5 - .65"	368-864	±.0001"
.65 - .8"	368-865	±.0001"
.8 - 1"	368-866	±.00015"
1 - 1.2"	368-867	±.00015"
1.2 - 1.6"	368-868	±.00015"
1.6 - 2"	368-869	±.00015"
2 - 2.5"	368-870	±.00015"
2.5 - 3"	368-871	±.00015"
3 - 3.5"	368-872	±.00015"
3.5 - 4"	368-873	±.00015"
4 - 5"	368-874	±.00025"
5 - 6"	368-875	±.00025"
6 - 7"	368-876	±.00025"
7 - 8"	368-877	±.00025"
8 - 9"	368-878	±.00025"
9 - 10"	368-879	±.00025"
10 - 11"	368-880	±.00025"
11 - 12"	368-881	±.00025"

### Complete Unit Set

Each set includes complete gages (micrometer head units and measuring heads for each size).

Metric				
Range	Order No.	Individual range	Setting rings included	Remarks
12 - 20mm	368-991	12-16, 16-20mm	ø16mm	with extension rod
20 - 50mm	368-992	20-25, 25-30, 30-40, 40-50mm	ø25mm, ø40mm	with extension rod
50 - 100mm	368-993	50-63, 62-75, 75-88, 87-100mm	ø62mm, ø87mm	with extension rod
100 - 200mm	368-994	100-125, 125-150, 150-175, 175-200mm	ø125mm, ø175mm	with extension rod

Inch				
Range	Order No.	Individual range	Setting rings included	Remarks
.5" - .8"	368-995	.5-.65", .65-.8"	.65" DIA.	with extension rod
.8" - 2"	368-996	.8-1", 1-1.2", 1.2-1.6", 1.6-2"	1" DIA., 1.6" DIA.	with extension rod
2" - 4"	368-997	2-2.5", 2.5-3", 3-3.5", 3.5-4"	2.5" DIA., 3.5" DIA.	with extension rod
4" - 8"	368-998	4-5", 5-6", 6-7", 7-8"	5" DIA., 7" DIA.	with extension rod

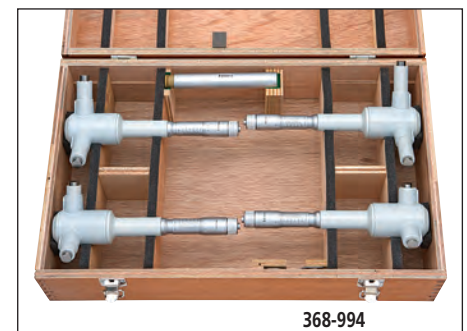

# Borematic

## SERIES 568 — ABSOLUTE Digimatic Snap Bore Gages

The Borematic enables the operator to take measurements more accurately and quicker than ever before. Once the origin point is set with the ORIGIN button, the Borematic retains the setting for the entire battery life. Therefore no longer repeated origin setting (presetting) is necessary.

### FEATURES

- TiN-coated measuring contact points provide excellent durability and impact resistance and allow the instrument to measure to the bottom of a blind hole.
- Large LCD digits of 8.5mm height for error-free reading.
- 330-degree rotatable display unit for easy reading at any angle.
- GO/NO-GO judgment function.
- The ABSOLUTE linear encoder eliminates over-speed errors.
- With SPC data output.
- Setting rings for origin point setting are optional.
- Can measure deep holes by attaching an optional extension rod.
- Measurement can be taken closer to the bottom of a blind bore.
- Supplied in fitted wooden case.



TiN coated contact points (" -10" suffix models only)

### SPECIFICATIONS

Metric	Individual		
Range	Order No.	Accuracy	Mass (g)
6 - 8mm	568-361	±5µm	480
8 - 10mm	568-362	±5µm	485
10 - 12mm	568-363	±5µm	485
12 - 16mm	568-364	±5µm	475
16 - 20mm	568-365	±5µm	480
20 - 25mm	568-366	±6µm	540
25 - 30mm	568-367	±6µm	555
30 - 40mm	568-368	±6µm	565
40 - 50mm	568-369	±6µm	610
50 - 63mm	568-370	±6µm	730
62 - 75mm	568-371	±6µm	740
75 - 88mm	568-372	±6µm	790
87 - 100mm	568-373	±6µm	800
100 - 113mm	568-374	±6µm	900
112 - 125mm	568-375	±6µm	910

Inch/Metric			
Range	Order No.	Accuracy	Mass (g)
.275 - .350" / 6.985 - 8.89mm	568-461	±.00025"	480
.350 - .425" / 8.89 - 10.795mm	568-462	±.00025"	485
.425 - .5" / 10.795 - 12.7mm	568-463	±.00025"	485
.50 - .65" / 12.7 - 16.51mm	568-464	±.00025"	475
.65 - .80" / 16.51 - 20.32mm	568-465	±.00025"	480
.8 - 1.0" / 20.32 - 25.4mm	568-466	±.0003"	540
1.0 - 1.2" / 25.4 - 30.48mm	568-467	±.0003"	555
1.2 - 1.6" / 30.48 - 40.64mm	568-468	±.0003"	565
1.6 - 2.0" / 40.64 - 50.8mm	568-469	±.0003"	610
2.0 - 2.5" / 50.8 - 63.5mm	568-470	±.0003"	730
2.5 - 3.0" / 63.5 - 76.2mm	568-471	±.0003"	740
3.0 - 3.5" / 76.2 - 88.9mm	568-472	±.0003"	790
3.5 - 4.0" / 88.9 - 101.6mm	568-473	±.0003"	800
4.0 - 4.5" / 101.6 - 114.3mm	568-474	±.0003"	900
4.5 - 5.0" / 114.3 - 127mm	568-475	±.0003"	910



### Technical Data

Accuracy: Refer to the list of specifications.

Resolution: 0.001mm or .00005"/0.001mm

Contact point: Carbide or TiN coating\*  
(\*over 12mm/.5" models)

Measuring method: Three-point method

Display: LCD

Battery: SR44 (1 pc.) (938882)

Battery life: Approx. 7,000 hours

### Functions

Zero/ABS, presetting, GO/NO-GO judgment, power on/off, inch/mm conversion (on inch/metric models only), SPC data output, data hold

### Optional Accessories

905338: SPC cable (1m / 40")

905409: SPC cable (2m / 80")

952322: Extension rod 100mm / 3.94"  
For range 6-12mm / .275-.5" models

952621: Extension rod 150mm / 5.9"  
For range 12-20mm / .5" - .8" models

952622: Extension rod 150mm / 5.9"  
For range 20-50mm / .8" - 2" models

952623: Extension rod 150mm / 5.9"  
For range 50-300mm / 2" - 12" models

-----: Setting ring (See page C-30.)

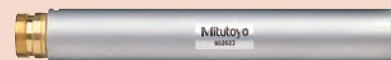



## Complete Unit Set

Each set includes complete gages display units and measuring heads for each size and extension rod.

### Metric

Range	Set Order No.	Individual Order No.	Setting rings included
6 - 12mm	568-955	568-361, 568-362 568-363	177-125 (ø8mm) 177-126 (ø10mm)
12 - 25mm	568-956	568-364, 568-365 568-366	177-177 (ø16mm) 177-286 (ø20mm)
25 - 50mm	568-957	568-367, 568-368 568-369	177-139 (ø25mm) 177-290 (ø40mm)
50 - 75mm	568-958	568-370 568-371	177-314 (ø62mm)
75 - 100mm	568-959	568-372 568-373	177-318 (ø87mm)

\*interchangeable contact points (4 sets)

### Inch/Metric

Range	Set Order No.	Individual Order No.	Setting rings included
.275" - .5" / 6.985 - 12.7mm	568-965	568-461, 568-462 568-463	177-179 (.35" DIA.) 177-283 (.425" DIA.)
.5" - 1" / 12.7 - 25.4mm	568-966	568-464, 568-465 568-466	177-182 (.65" DIA.) 177-287 (.8" DIA.)
1" - 2" / 25.4 - 50.8mm	568-967	568-467, 568-468 568-469	177-289 (1.2" DIA.) 177-291 (1.6" DIA.)
2" - 3" / 50.8 - 76.2mm	568-968	568-470 568-471	177-315 (2.5" DIA.)
3" - 4" / 76.2 - 101.6mm	568-969	568-472 568-473	177-319 (3.5" DIA.)

## Interchangeable Head Set

Each set includes one display unit with interchangeable measuring heads of the sizes specified and extension rod.

### Metric

Range	Set Order No.	Display Unit	Adaptor Supplied	Individual Head No.	Setting rings included
6 - 12mm	568-924	568-014	954595	04AZB136 04AZB137 04AZB138	177-125 (ø8mm) 177-126 (ø10mm)
12 - 25mm	568-925	568-014	216556 568-926	04AZA719 04AZA720 04AZA728	177-177 (ø16mm) 177-286 (ø20mm)
25 - 50mm	568-926	568-014	216557	04AZA729 04AZA737 04AZA738	177-288 (ø30mm) 177-290 (ø40mm)
50 - 100mm	568-927	568-014	216558	04AZA750, 04AZA751, 04AZA752 04AZA753	177-314 (ø62mm) 177-318 (ø87mm)

\*interchangeable anvils (Total 4 sets)

### Inch/Metric

Range	Set Order No.	Display Unit	Adaptor Supplied	Individual Head No.	Setting rings included
.275" - .5" / 6.985 - 12.7mm	568-928	568-015	954595	04AZB139 04AZB140 04AZB141	177-179 (.35" DIA.) 177-283 (.425" DIA.)
.5" - 1" / 12.7 - 25.4mm	568-929	568-015	216556 216557	04AZA721 04AZA722 04AZA730	177-182 (.65" DIA.) 177-287 (.8" DIA.)
1" - 2" / 25.4 - 50.8mm	568-930	568-015	216557	04AZA731 04AZA739 04AZA740	177-289 (1.2" DIA.) 177-291 (1.6" DIA.)
2" - 4" / 50.8 - 101.6mm	568-936	568-015	216558	04AZA754 04AZA755 04AZA756 04AZA757	177-315 (2.5" DIA.) 177-319 (3.5" DIA.)

\*interchangeable anvils (Total 4 sets)

## Interchangeable Contact Head Set



568-924

## Complete Unit Set



568-959

## DIMENSIONS

### Measuring a Blind Hole

The measuring pins held in the jaws permit measuring the diameter of a blind hole right down to the bottom.

Unit: mm

Range	L	a	b	c
6 - 12mm / .275 - .5"	83	2	—	2.5
12 - 20mm / .5 - .8"	53	0.3	5.6	3.5
20 - 30mm / .8 - 1.2"	59	0.3	8.3	5.2
30 - 50mm / 1.2 - 2"	67	0.3	13	10
50 - 125mm / 2 - 5"	75	0.3	17	14

( ) : 50-125mm model

# Holtest/Digimatic Holtest/Borematic

## SERIES 368, 468, 568 Replacement Head Assy List

TiN-coated measuring contact head assy

Head Assy Order No.	Measuring Range	HT(Type I)		HTD		SBM	
		Order No.	Model	Order No.	Model	Order No.	Model
04AZB136	6 - 8mm	368-161	HT-8R	468-161	HTD-8R	568-361	SBM-8C
04AZB137	8 - 10mm	368-162	HT-10R	468-162	HTD-10R	568-362	SBM-10C
04AZB138	10 - 12mm	368-163	HT-12R	468-163	HTD-12R	568-363	SBM-12C
04AZA719	12 - 16mm	368-164	HT-16R	468-164	HTD-16R	568-364	SBM-16C
04AZA720	16 - 20mm	368-165	HT-20R	468-165	HTD-20R	568-365	SBM-20C
04AZA728	20 - 25mm	368-166	HT-25R	468-166	HTD-25R	568-366	SBM-25C
04AZA729	25 - 30mm	368-167	HT-30R	468-167	HTD-30R	568-367	SBM-30C
04AZA737	30 - 40mm	368-168	HT-40R	468-168	HTD-40R	568-368	SBM-40C
04AZA738	40 - 50mm	368-169	HT-50R	468-169	HTD-50R	568-369	SBM-50C
04AZA750	50 - 63mm	368-170	HT-63R	468-170	HTD-63R	568-370	SBM-63C
04AZA751	62 - 75mm	368-171	HT-75R	468-171	HTD-75R	568-371	SBM-75C
04AZA752	75 - 88mm	368-172	HT-88R	468-172	HTD-88R	568-372	SBM-88C
04AZA753	87 - 100mm	368-173	HT-100R	468-173	HTD-100R	568-373	SBM-100C
04AZA775	100 - 125mm	368-174	HT-125R	468-174	HTD-125R	—	—
04AZA776	125 - 150mm	368-175	HT-150R	468-175	HTD-150R	—	—
04AZA777	150 - 175mm	368-176	HT-175R	468-176	HTD-175R	—	—
04AZA778	175 - 200mm	368-177	HT-200R	468-177	HTD-200R	—	—
04AZA779	200 - 225mm	368-178	HT-225R	468-178	HTD-225R	—	—
04AZA780	225 - 250mm	368-179	HT-250R	468-179	HTD-250R	—	—
04AZA781	250 - 275mm	368-180	HT-275R	468-180	HTD-275R	—	—
04AZA782	275 - 300mm	368-181	HT-300R	468-181	HTD-300R	—	—
04AZB139	.275 - .35"	368-261	HT-.35"R	468-261	HTD-.35"R	568-461	SBM-.35"C
04AZB140	.35 - .425"	368-262	HT-.425"R	468-262	HTD-.425"R	568-462	SBM-.425"C
04AZB141	.425 - .5"	368-263	HT-.5"R	468-263	HTD-.5"R	568-463	SBM-.5"C
04AZA721	.5 - .65"	368-264	HT-.65"R	468-264	HTD-.65"R	568-464	SBM-.65"C
04AZA722	.65 - .8"	368-265	HT-.8"R	468-265	HTD-.8"R	568-465	SBM-.8"C
04AZA730	.8 - 1"	368-266	HT-1"R	468-266	HTD-1"R	568-466	SBM-1"C
04AZA731	1 - 1.2"	368-267	HT-1.2"R	468-267	HTD-1.2"R	568-467	SBM-1.2"C
04AZA739	1.2 - 1.6"	368-268	HT-1.6"R	468-268	HTD-1.6"R	568-468	SBM-1.6"C
04AZA740	1.6 - 2"	368-269	HT-2"R	468-269	HTD-2"R	568-469	SBM-2"C
04AZA754	2 - 2.5"	368-270	HT-2.5"R	468-270	HTD-2.5"R	568-470	SBM-2.5"C
04AZA755	2.5 - 3"	368-271	HT-3"R	468-271	HTD-3"R	568-471	SBM-3"C
04AZA756	3 - 3.5"	368-272	HT-3.5"R	468-272	HTD-3.5"R	568-472	SBM-3.5"C
04AZA757	3.5 - 4"	368-273	HT-4"R	468-273	HTD-4"R	568-473	SBM-4"C
04AZA783	4 - 5"	368-274	HT-5"R	468-274	HTD-5"R	—	—
04AZA784	5 - 6"	368-275	HT-6"R	468-275	HTD-6"R	—	—
04AZA785	6 - 7"	368-276	HT-7"R	468-276	HTD-7"R	—	—
04AZA786	7 - 8"	368-277	HT-8"R	468-277	HTD-8"R	—	—
04AZA787	8 - 9"	368-278	HT-9"R	468-278	HTD-9"R	—	—
04AZA788	9 - 10"	368-279	HT-10"R	468-279	HTD-10"R	—	—
04AZA789	10 - 11"	368-280	HT-11"R	468-280	HTD-11"R	—	—
04AZA790	11 - 12"	368-281	HT-12"R	468-281	HTD-12"R	—	—
04AZA941	100 - 113mm	—	—	—	—	568-374	SBM-113C
04AZA942	112 - 125mm	—	—	—	—	568-375	SBM-125C
04AZA943	4 - 4.5"	—	—	—	—	568-474	SBM-4.5"C
04AZA944	4.5 - 5"	—	—	—	—	568-475	SBM-5"C

# Tubular Inside Micrometers

## SERIES 133 — Single Rod Type

### FEATURES

- With locking clamp.
- Zero point can be readjusted by rotating the micrometer head sleeve. A key wrench is supplied.
- Clear, crisp graduations on the satin chrome finished micrometer head.
- Carbide-tipped measuring faces.
- Supplied in fitted plastic case. Over 200mm / 8" supplied in wooden case.

### Technical Data

Accuracy: Refer to the list of specifications.  
Graduation: 0.01mm or .001"

### Optional Accessories

---- : Setting ring (See page C-30.)

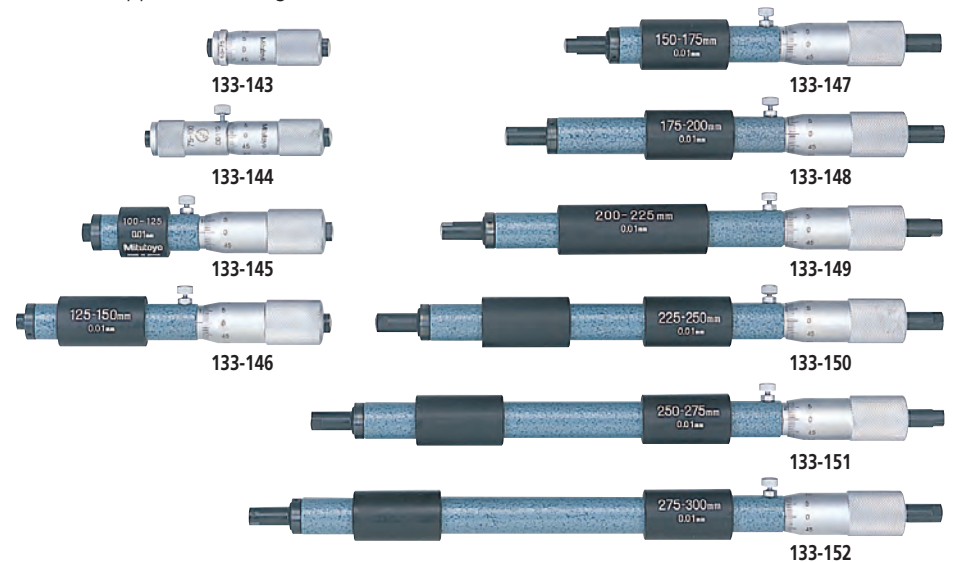

### SPECIFICATIONS

Metric		Individual
Range	Order No.	Accuracy
50 - 75mm	133-143	±3µm
75 - 100mm	133-144	±4µm
100 - 125mm	133-145	±5µm
125 - 150mm	133-146	±5µm
150 - 175mm	133-147	±5µm
175 - 200mm	133-148	±5µm
200 - 225mm	133-149	±5µm
225 - 250mm	133-150	±6µm
250 - 275mm	133-151	±6µm
275 - 300mm	133-152	±6µm
300 - 325mm	133-153	±7µm
325 - 350mm	133-154	±7µm
350 - 375mm	133-155	±7µm
375 - 400mm	133-156	±8µm
400 - 425mm	133-157	±8µm
425 - 450mm	133-158	±8µm
450 - 475mm	133-159	±9µm
475 - 500mm	133-160	±9µm
500 - 525mm	133-161	±9µm
525 - 550mm	133-162	±10µm
550 - 575mm	133-163	±10µm
575 - 600mm	133-164	±10µm
600 - 625mm	133-165	±11µm
625 - 650mm	133-166	±11µm
650 - 675mm	133-167	±11µm
675 - 700mm	133-168	±12µm

Metric		Individual
Range	Order No.	Accuracy
700 - 725mm	133-169	±12µm
725 - 750mm	133-170	±12µm
750 - 775mm	133-171	±13µm
775 - 800mm	133-172	±13µm
800 - 825mm	133-173	±13µm
825 - 850mm	133-174	±14µm
850 - 875mm	133-175	±14µm
875 - 900mm	133-176	±14µm
900 - 925mm	133-177	±15µm
925 - 950mm	133-178	±15µm
950 - 975mm	133-179	±15µm
975 - 1000mm	133-180	±16µm

Inch		Individual
Range	Order No.	Accuracy
2" - 3"	133-223	±.00015"
3" - 4"	133-224	±.0002"
4" - 5"	133-225	±.00025"
5" - 6"	133-226	±.00025"
6" - 7"	133-227	±.00025"
7" - 8"	133-228	±.00025"
8" - 9"	133-229	±.00025"
9" - 10"	133-230	±.0003"
10" - 11"	133-231	±.0003"
11" - 12"	133-232	±.0003"

# Tubular Inside Micrometers

## SERIES 133

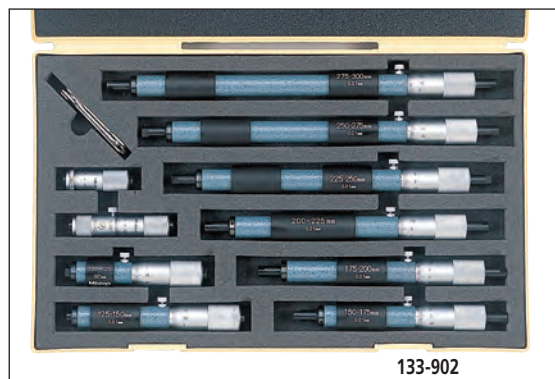

133-902

Metric Micrometer set		
Range	Order No.	Included in set
50 - 150mm (4 pcs. set)	133-901	<ul style="list-style-type: none"> <li>• 133-143, 133-144, 133-145, 133-146</li> <li>• with fitted case</li> </ul>
50 - 300mm (10 pcs. set)	133-902	<ul style="list-style-type: none"> <li>• 133-143, 133-144, 133-145, 133-146, 133-147, 133-148, 133-149, 133-150, 133-151, 133-152</li> <li>• with fitted case</li> </ul>

Inch Micrometer set		
Range	Order No.	Included in set
2" - 6" (4 pcs. set)	133-903	<ul style="list-style-type: none"> <li>• 133-223, 133-224, 133-225, 133-226</li> <li>• with fitted case</li> </ul>
2" - 12" (10 pcs. set)	133-904	<ul style="list-style-type: none"> <li>• 133-223, 133-224, 133-225, 133-226, 133-227, 133-228, 133-229, 133-230, 133-231, 133-232</li> <li>• with fitted case</li> </ul>

## DIMENSIONS

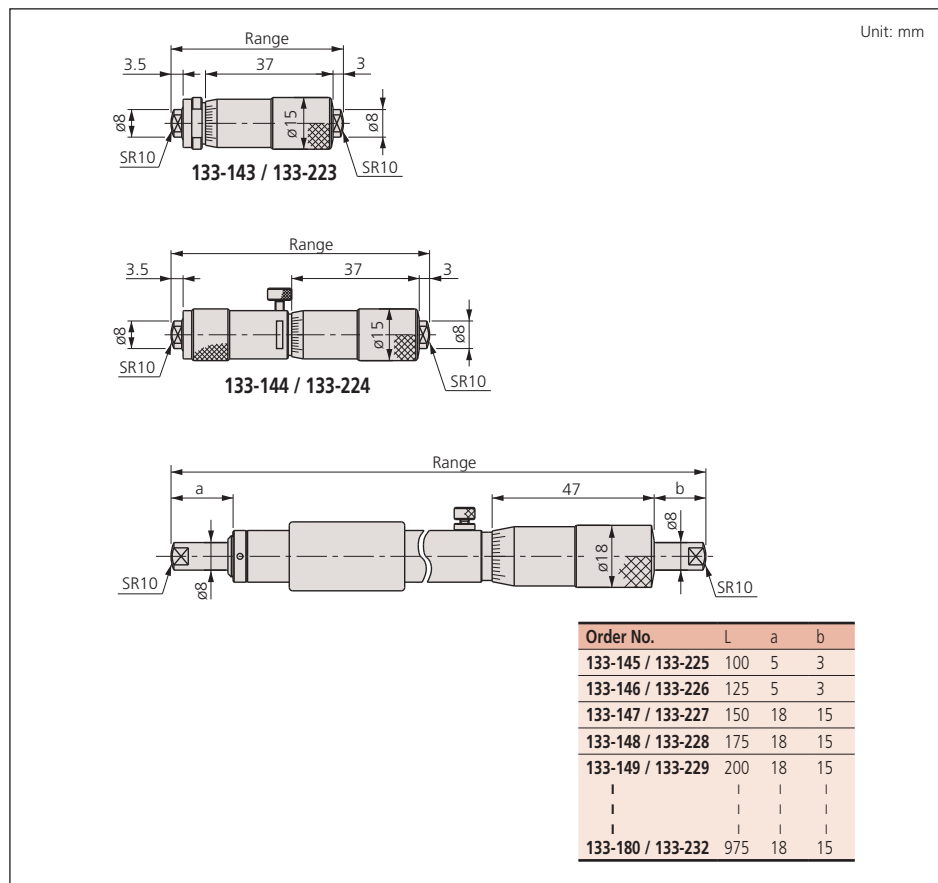



# Inside Micrometers

## SERIES 141 — Interchangeable Rod Type

### FEATURES

- Wide range of ID measurements with interchangeable rods.
- Each interchangeable rod is marked with its measuring range.
- The sizes of interchangeable rods can be adjusted with spacing collars.
- Both micrometer head and furnished rods are satin-chrome finished throughout.
- Supplied in fitted plastic case. Over 1000mm / 40" supplied in wooden case.

### Technical Data

Metric Model

Accuracy:  $\pm(6+L/50)\mu\text{m}^*$   
 \*L=Maximum measuring length (mm)  
 Fraction rounded up

Inch Model

Accuracy:  $\pm\{.00024 + (.00004 \times R/2)\}^*^*$   
 \*R=Maximum measuring length (inch)  
 Fraction rounded up

Graduation: 0.01mm or .001"

### Optional Accessories

---- : Setting ring (See page C-30.)



141-233



141-101



When using the extension rod

### DIMENSIONS

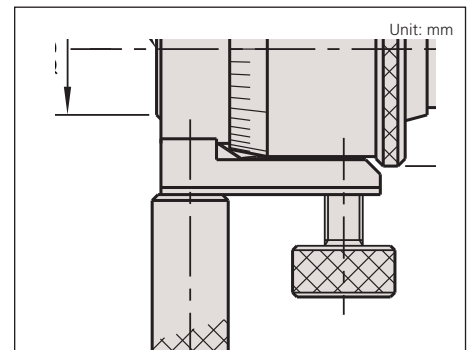

### SPECIFICATIONS

#### Metric

Range	Order No.	Travel of micrometer head	Remarks
25 - 32mm	141-001 / 141-003*	7mm	—
25 - 50mm	141-101 / 141-103*	7mm	with 2 rods
50 - 63mm	141-025 / 141-027*	13mm	—
50 - 200mm	141-205 / 141-211*	13mm	with 3 rods
50 - 300mm	141-206 / 141-212*	13mm	with 5 rods
200 - 225mm	141-009 / 141-011*	25mm	—
200 - 500mm	141-117	25mm	with 3 rods
200 - 1000mm	141-118	25mm	with 8 rods

\*with carbide tipped face

#### Inch

Range	Order No.	Travel of micrometer head	Remarks
1" - 1.25"	141-002 / 141-004*	.25"	—
1" - 2"	141-102 / 141-104*	.25"	with 2 rods
2" - 2.5"	141-026 / 141-028*	.5"	—
2" - 8"	141-208 / 141-214*	.5"	with 3 rods
2" - 12"	141-233 / 141-215*	.5"	with 5 rods
8" - 9"	141-010 / 141-012*	1"	—
8" - 20"	141-121	1"	with 3 rods
8" - 40"	141-122	1"	with 8 rods

\*with carbide tipped face

# Digimatic Tubular Inside Micrometers

**SERIES 337 — Extension Rod Type / SERIES 339 — Extension Pipe Type**

## FEATURES

- Wide range of ID measurements by combining extension rods (pipes) and anvils with the micrometer head.
- The 339 Series uses highly-durable extension pipes.
- Carbide-tipped measuring faces.
- Supplied in wooden case.



337-303



339-304



### Metric — Extension rod type

Range	Order No.	Travel of micrometer head	Extension rods
200 - 225mm	337-101	25mm	—
200 - 1000mm	337-301	25mm	25mm, 50mm, 100mm (2 pcs.), 200mm, 300mm
200 - 1500mm	337-302	25mm	25mm, 50mm, 100mm, 200mm, 300mm (3 pcs.)

### Inch/Metric — Extension rod type

Range	Order No.	Travel of micrometer head	Extension rods
8 - 9" / 203.2 - 228.6mm	337-102	1"	—
8 - 40" / 203.2 - 1016mm	337-303	1"	1", 2", 4" (2 pcs.), 8", 12"
8 - 60" / 203.2 - 1524mm	337-304	1"	1", 2", 4", 8", 12" (3 pcs.)

### Metric — Extension pipe type

Range	Order No.	Travel of micrometer head	Extension pipes
200 - 225mm	339-101	25mm	—
200 - 1000mm	339-301	25mm	25mm, 50mm, 100mm, 200mm, 400mm
200 - 2000mm	339-302	25mm	25mm, 50mm, 100mm, 200mm (2 pcs.), 400mm (3 pcs.)

### Inch/Metric — Extension pipe type

Range	Order No.	Travel of micrometer head	Extension pipes
8 - 9" / 203.2 - 228.6mm	339-102	1"	—
8 - 40" / 203.2 - 1016mm	339-303	1"	1", 2", 4", 8", 16"
8 - 60" / 203.2 - 1524mm	339-304	1"	1", 2", 4", 8" (2 pcs.), 16" (3 pcs.)

## DIMENSIONS

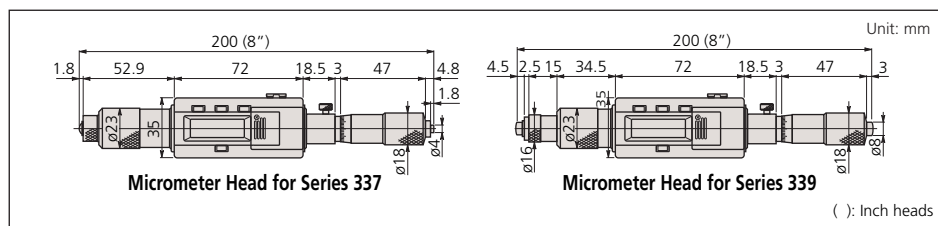

## Technical Data

Metric Model

Accuracy:  $\pm(3+n+L/50)\mu\text{m}^*$   
 \* n=Number of rod, L=Maximum measuring length (mm), Fraction rounded up, Excluding quantizing error

Inch Model

Accuracy:  $\pm\{.00012+ (.00004 \times R/2)\}^**$   
 \* R=Maximum measuring length (inch) Fraction rounded up

Resolution: 0.001mm or .0001"/0.001mm

Display: LCD

Battery: SR44 (1 pcs.), 938882

Battery life: Approx. 8 months under normal use

## Function

Zero/ABS, Data hold, Data output, Preset, inch/mm conversion (inch/mm models)

Alarm: Low voltage, Counting value composition error

## Optional Accessories

05CZA662: SPC cable (1m)

05CZA663: SPC cable (2m)

-----: Setting ring (See page C-30.)



# Tubular Inside Micrometers

## SERIES 137 — Extension Rod Type

### FEATURES

- Wide range of ID measurements by combining extension rods (pipes) and anvils with the micrometer head.
- Carbide-tipped measuring faces are available.
- Supplied in fitted plastic case except 1500 mm / 60" come in wooden case.



137-011

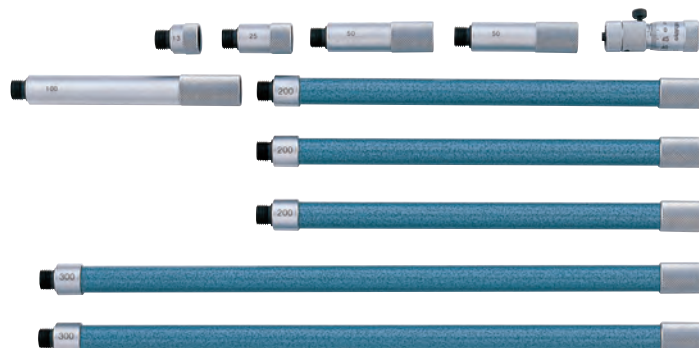

137-205

### Technical Data

Metric Model

Accuracy:  $\pm(3+n+L/50)\mu\text{m}$   
 L=Maximum measuring length (mm), Fraction rounded up

Inch Model

Accuracy:  $\pm\{.00012+n+(\.00004 \times R/2)\}^*$   
 R=Maximum measuring length (inch), Fraction rounded up

Graduation: 0.01mm or .001"

### Optional Accessories

---- : Setting ring (See page C-30.)

### SPECIFICATIONS

#### Metric — Extension rod type

Range	Order No.	Travel of micrometer head	Extension rods
50 - 63mm	137-011 / 137-013*	13mm	—
50 - 150mm	137-201 / 137-206*	13mm	13mm, 25mm, 50mm
50 - 300mm	137-202 / 137-207*	13mm	13mm, 25mm, 50mm (2 pcs.), 100mm
50 - 500mm	137-203 / 137-208*	13mm	13mm, 25mm, 50mm (2 pcs.), 100mm, 200mm
50 - 1000mm	137-204 / 137-209*	13mm	13mm, 25mm, 50mm (2 pcs.), 100mm, 200mm (2 pcs.), 300mm
50 - 1500mm	137-205 / 137-210*	13mm	13mm, 25mm, 50mm (2 pcs.), 100mm, 200mm (3pcs.), 300mm (2 pcs.)

\*with carbide tipped face

#### Inch — Extension rod type

Range	Order No.	Travel of micrometer head	Extension rods
2" - 2.5"	137-012 / 137-014*	.5"	—
2" - 6"	137-211 / 137-216*	.5"	.5", 1", 2"
2" - 12"	137-212 / 137-217*	.5"	.5", 1", 2" (2 pcs.), 4"
2" - 20"	137-213 / 137-218*	.5"	.5", 1", 2" (2 pcs.), 4", 8"
2" - 40"	137-214 / 137-219*	.5"	.5", 1", 2" (2 pcs.), 4", 8" (2 pcs.), 12"
2" - 60"	137-215 / 137-220*	.5"	.5", 1", 2" (2 pcs.), 4", 8" (3 pcs.), 12" (2 pcs.)

\*with carbide tipped face

### DIMENSIONS

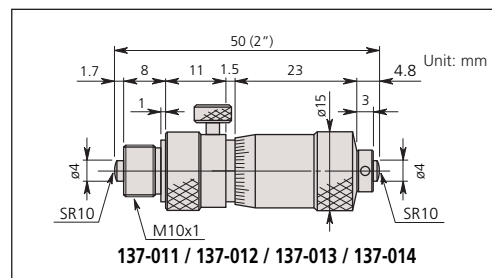

# Tubular Inside Micrometers

## SERIES 139 — Extension Pipe Type

### FEATURES

- Wide range of ID measurements by combining extension pipes and anvils with the micrometer head.
- Supplied in fitted wooden case except 500 mm / 20" come in plastic case.

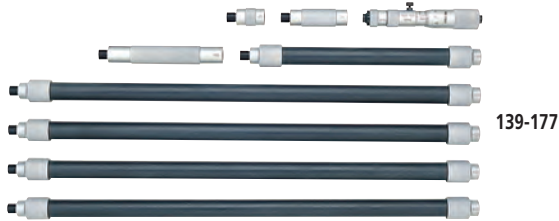

### Metric — Extension pipe type

Range	Order No.	Travel of micrometer head	Extension pipes
100 - 125mm	139-001	25mm	—
100 - 500mm	139-173	25mm	25mm, 50mm, 100mm, 200mm
100 - 900mm	139-174	25mm	25mm, 50mm, 100mm, 200mm, 400mm
100 - 1300mm	139-175	25mm	25mm, 50mm, 100mm, 200mm, 400mm (2 pcs.)
100 - 1700mm	139-176	25mm	25mm, 50mm, 100mm, 200mm, 400mm (3 pcs.)
100 - 2100mm	139-177	25mm	25mm, 50mm, 100mm, 200mm, 400mm (4 pcs.)

### Inch — Extension pipe type

Range	Order No.	Travel of micrometer head	Extension pipes
4" - 5"	139-002	1"	—
4" - 20"	139-178	1"	1", 2", 4", 8"
4" - 36"	139-179	1"	1", 2", 4", 8", 16"
4" - 52"	139-180	1"	1", 2", 4", 8", 16" (2 pcs.)
4" - 68"	139-181	1"	1", 2", 4", 8", 16" (3 pcs.)
4" - 84"	139-182	1"	1", 2", 4", 8", 16" (4 pcs.)



139-201

### Inch — Extension pipe type

Range	Order No.	Travel of micrometer head	Extension pipes	Remarks
1.5 - 2"	139-004	.5"	—	—
4 - 5"	139-006	1"	—	—
1.5 - 12"	139-201	.5"	.5", 1", 2", 2.5", 3", 3.5", 4", 6"	Includes 139-004
4 - 40"	139-202	1"	1", 2", 3", 6", 9", 12", 14", 16", 17", 19"	Includes 139-006

### DIMENSIONS

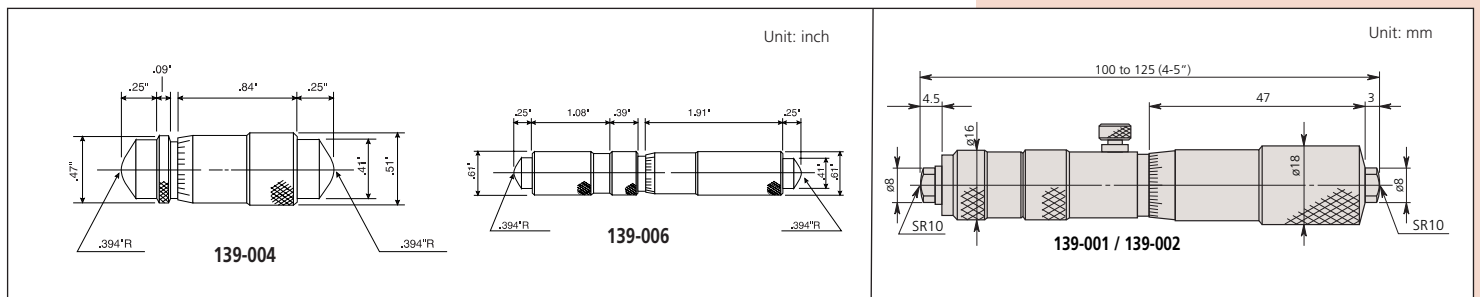

### Technical Data

Metric Model

Accuracy:

- Series 139:  $\pm(3+n+L/50)\mu\text{m}$   
L=Maximum measuring length (mm), Fraction rounded up

Inch Model

Accuracy:

- Series 139:  $\pm(.00012+m+(\.00004 \times R/2))^*$   
R=Maximum measuring length (inch), Fraction rounded up

Graduation: 0.01mm or .001"

### Optional Accessories

-----: Setting ring (See page C-30.)



# Tubular Inside Micrometers

## SERIES 140 — Extension Pipe Type

### Technical Data

Metric Model  
 Accuracy:  $\pm(3+n+L/50)\mu\text{m}^*$   
\*n=Number of rod, L=Maximum measuring length (mm), Fraction rounded up

Inch Model  
 Accuracy:  $\pm\{.00012+m+(.00004 \times R/2)\}^*$   
\*n=Number of rod, L=Maximum measuring length (mm), Fraction rounded up

Graduation: 0.01mm or .001"

### Optional Accessories

----- : Setting ring (See page C-30.)

### FEATURES

- Wide range of ID measurements by combining extension rods (pipes) and anvils with the micrometer head.
- The Series 140 use highly-durable/ large-diameter extension pipes.
- Supplied in fitted wooden case.

#### Metric — Extension pipe type

Range	Order No.	Travel of micrometer head	Extension pipes
1000 - 2000mm	<b>140-157</b>	50mm	50mm, 100mm (2 pcs.), 200mm, 500mm
1000 - 3000mm	<b>140-158</b>	50mm	50mm, 100mm (2 pcs.), 200mm, 500mm, 1000mm
1000 - 4000mm	<b>140-159</b>	50mm	50mm, 100mm (2 pcs.), 200mm, 500mm, 1000mm (2 pcs.)
1000 - 5000mm	<b>140-160</b>	50mm	50mm, 100mm (2 pcs.), 200mm, 500mm, 1000mm (3 pcs.)

#### Inch — Extension pipe type

Range	Order No.	Travel of micrometer head	Extension pipes
40" - 80"	<b>140-161</b>	2"	2", 4" (2 pcs.), 8", 20"
40" - 120"	<b>140-162</b>	2"	2", 4" (2 pcs.), 8", 20", 40"
40" - 160"	<b>140-163</b>	2"	2", 4" (2 pcs.), 8", 20", 40" (2 pcs.)
40" - 200"	<b>140-164</b>	2"	2", 4" (2 pcs.), 8", 20", 40" (3 pcs.)

### DIMENSIONS

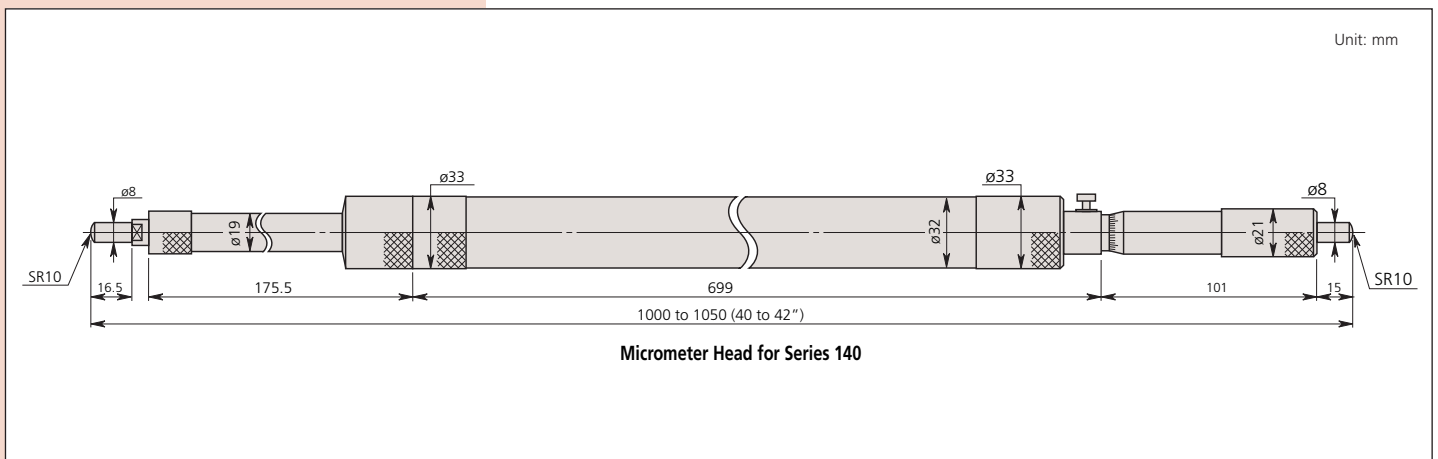

# Inside Micrometers

## SERIES 345, 145 — Caliper Type

### FEATURES

- Caliper type jaws are made of high-grade, tool steel.
- Locking clamp for positive locking of spindle.
- Satin-chrome finished.
- A special holder is available to be used with Mitutoyo Micrometer Stand.
- Supplied in fitted plastic case. Over 175mm / 4" supplied in wooden case.



345-350-10



145-193

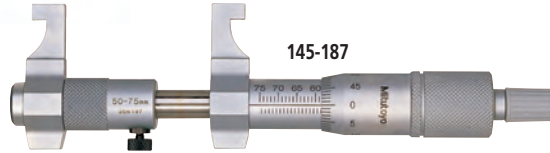

145-187

### SPECIFICATIONS

Metric		
Range	Order No.	Accuracy
5 - 30mm	345-250-10	±5µm
25 - 50mm	345-251-10	±6µm

Inch/Metric		
Range	Order No.	Accuracy
.2 - 1.2" / 5-30mm	345-350-10	±.00025"
1 - 2" / 25-50mm	345-351-10	±.0003"

Metric		
Range	Order No.	Accuracy
5 - 30mm	145-185	±5µm
25 - 50mm	145-186	±6µm
50 - 75mm	145-187	±7µm
75 - 100mm	145-188	±8µm
100 - 125mm	145-189	±9µm
125 - 150mm	145-190	±9µm
150 - 175mm	145-191	±10µm
175 - 200mm	145-192	±10µm
200 - 225mm	145-217	±11µm
225 - 250mm	145-218	±11µm
250 - 275mm	145-219	±12µm
275 - 300mm	145-220	±12µm

Inch		
Range	Order No.	Accuracy
.2 - 1.2"	145-193	±.00025"
1 - 2"	145-194	±.0003"
2 - 3"	145-195	±.00035"
3 - 4"	145-196	±.0004"

### DIMENSIONS

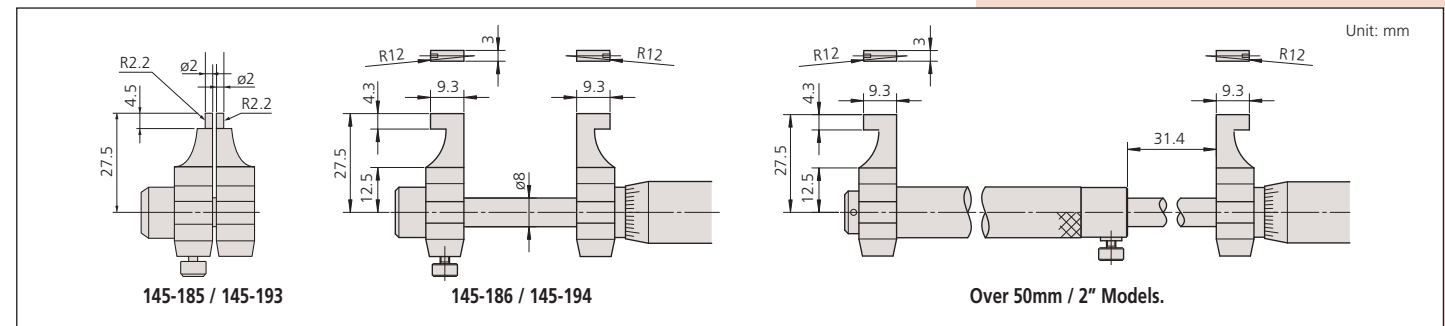

### Technical Data

Accuracy: Refer to the list of specifications.  
(excluding quantizing error for digital models)  
Resolution\*: 0.01mm or .00005"/0.001mm  
Graduation\*\*: 0.01mm or .001"  
Measuring faces: Carbide tipped  
Display\*: LCD  
Battery\*: SR44 (1 pc.), 938882  
Battery life\*: Approx. 1.2 years under normal use  
\*Digital models \*\*Analog models

### Function of Digital Model

Origin-set, Zero-setting, Data hold, Data output, inch/mm conversion (inch/mm models)  
Alarm: Low voltage, Counting value composition error  
Function Lock  
2 Presets

### Optional Accessories

- 05CZA662: SPC cable with data switch 1m / 40"
- 05CZA663: SPC cable with data switch 2m / 80"
- : Setting ring (See page C-30.)
- 300401: Cap for stand holder
- 300400: Stand holder

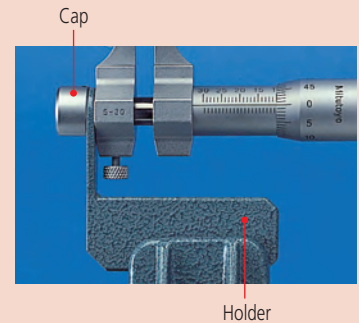



# Inside Micro Checker

## SERIES 515

### FEATURES

- The Inside Micro Checker is designed to efficiently check the zero point of a tubular inside micrometer.
- Each measuring block is made of zirconia-based ceramic and it is free from deterioration and dimensional changes over time.

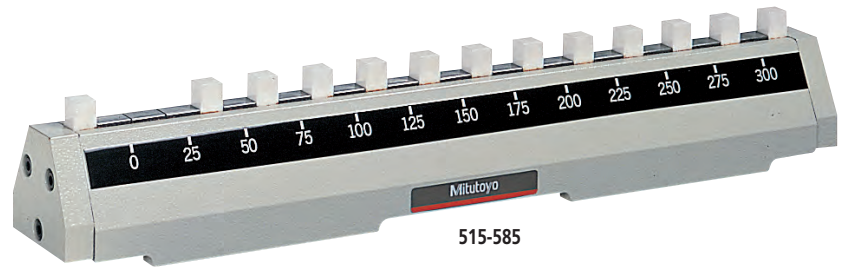

515-585



Standard accessory

### Technical Data

Block pitch accuracy:  $\pm(0.001+L/150000)\text{mm}^*$   
 \*L= Length to check (mm)

### Optional Accessories

- 602160:** Wooden case for 300mm Inside Micro Checker  
**602163:** Wooden case for 600mm Inside Micro Checker

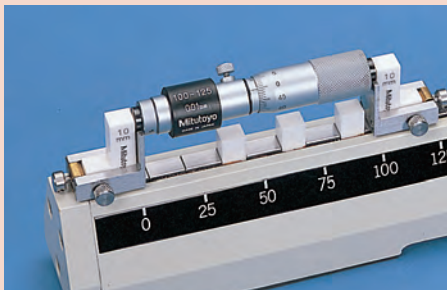

### SPECIFICATIONS

Range	Order No.	Length to check
300mm	<b>515-585</b>	25, 50, 75, 100, 125, 150, 175, 200, 225, 250, 275, 300mm
600mm	<b>515-586</b>	25, 50, 75, 100, 125, 150, 175, 200, 225, 250, 275, 300, 325, 350, 375, 400, 425, 450, 475, 500, 525, 550, 575, 600mm

### DIMENSIONS

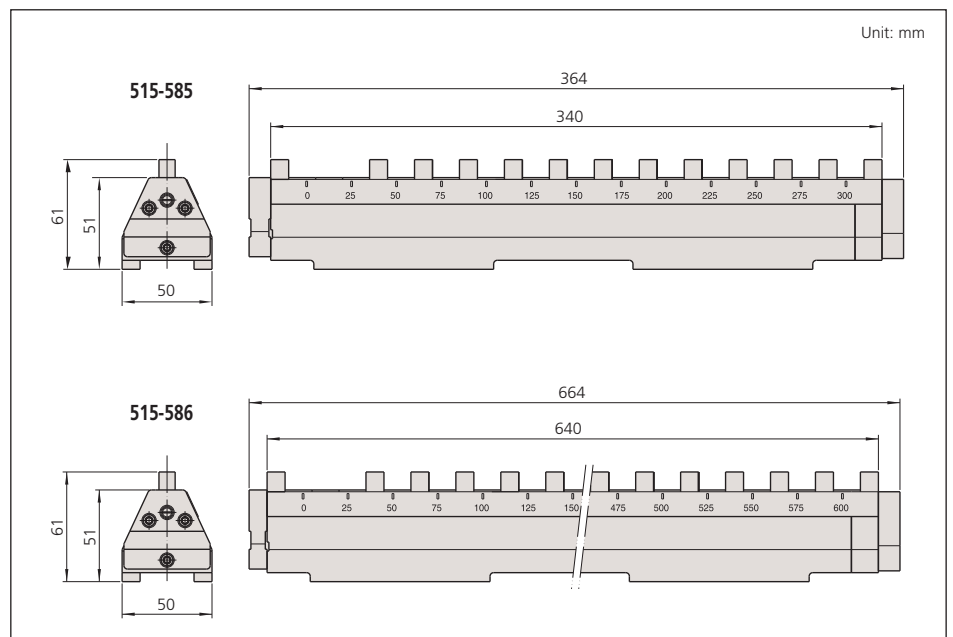

# Bore Gages

## SERIES 511 — for Small Holes

### FEATURES

- Its interchangeable anvils are made of alloyed steel.
- The dial indicator is fully protected by a rugged cover.

### SPECIFICATIONS

#### Metric    Gage Stem $\varnothing$ 8mm

Measuring Range	Order No. Without Dial Gage	Order No. With 2046SB Graduation 0.01mm	Order No. With 2109SB-10 Graduation 0.001mm	Number of Anvils	Number of Spacers
6 - 10mm	511-209*	511-211	511-210	9	1
10 - 18.5mm	511-201*	511-204	511-203	9	1

\*Does not come supplied with Dial Gage Protector Cover (21DZA000)

#### Inch    Gage Stem Dia .375"

Measuring Range	Order No. Without Dial Gage	Order No. With 2922SB Graduation .0005"	Order No. With 2923SB-10 Graduation .0001"	Number of Anvils	Number of Spacers
.24 - .4"	511-214*	511-213	511-212	9	1
.4 - .74"	511-205*	511-207	511-206	9	1

\*Does not come supplied with Dial Gage Protector Cover (21DZA000)

### DIMENSIONS

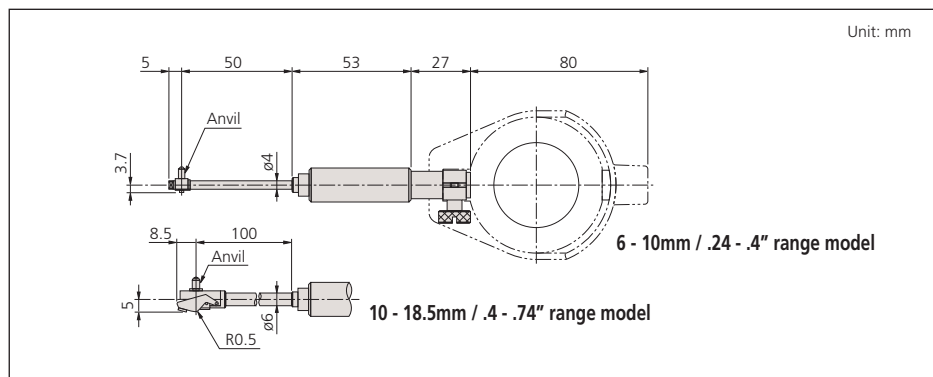

511-204

### Technical Data

Accuracy:  $5\mu\text{m}$  / .0002"

Indication stability:  $2\mu\text{m}$  / .00008"

Graduation: 0.01mm, 0.001mm, .0005" or .0001"

### Measuring Heads

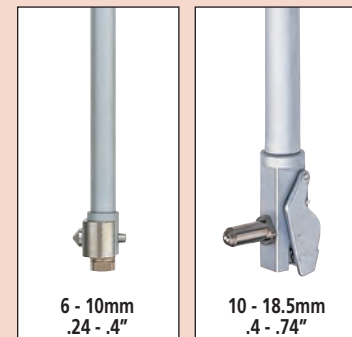

### Optional Accessories

21DZA000: Dial Gage Protector Cover

-----: Setting ring (See page C-30.)



# Bore Gages

## SERIES 511—Standard Type

Mitutoyo offers a complete selection of Bore Gages, all of them with interchangeable anvils and necessary accessories to perform close tolerance ID measurements.

### FEATURES

- Most popular Bore Gages.
- Carbide-tipped contact points for durability.
- The dial indicator is fully protected by a rugged cover.
- Optional extension rods can be attached for measuring deep holes.



511-743

### SPECIFICATIONS

**Inch** — Gage Stem  $\varnothing$  3/8"

Measuring Range	Order No. Without Indicator	Order No. With 2922SB Graduation .0005"	Order No. With 2923SB-10 Graduation .0001"	Number of Anvils	Number of Spacers
.7 - 1.4"	511-731*	511-741	511-751	9	2
1.4 - 2.5"	511-732*	511-742	511-752	6	4
2.0 - 6.0"	511-733*	511-743	511-753	11 (2" sub anvil)	4
4.0 - 6.5"	511-734*	511-744	511-754	13	4
6.5 - 10"	511-735*	511-745	511-755	6	7
10 - 16"	511-736*	511-746	511-756	5 (3" sub anvil)	7
.7 - 6"	—	511-931	511-932	26 (2" sub anvil)	10

\*Does not come supplied with Dial Gage Protector Cover ( 21DZA000 )

**Metric** — Gage Stem  $\varnothing$  8mm

Measuring Range	Order No. Without Indicator	Order No. With 2046SB Graduation 0.01mm	Order No. With 2109SB-10 Graduation 0.001mm	Number of Anvils	Number of Spacers
18 - 35mm	511-701*	511-711	511-721	9	2
35 - 60mm	511-702*	511-712	511-722	6	4
50 - 150mm	511-703*	511-713	511-723	11 (50mm Sub Anvil)	4
100 - 160mm	511-704*	511-714	511-724	13	4
160 - 250mm	511-705*	511-715	511-725	6	7
250 - 400mm	511-706*	511-716	511-726	5 (75mm Sub Anvil)	7
18 - 150mm	—	511-921 (3 pc set)	511-922 (3 pc set)	26 (50mm Sub Anvil)	10

\*Does not come supplied with Dial Gage Protector Cover ( 21DZA000 )

### Technical Data

Accuracy:  $2\mu\text{m} / .00008"$

Indication stability:  $1\mu\text{m} / .00004"$

Graduation: 0.01mm, 0.001mm, .0005" or .0001"



511-931

## Contact Point

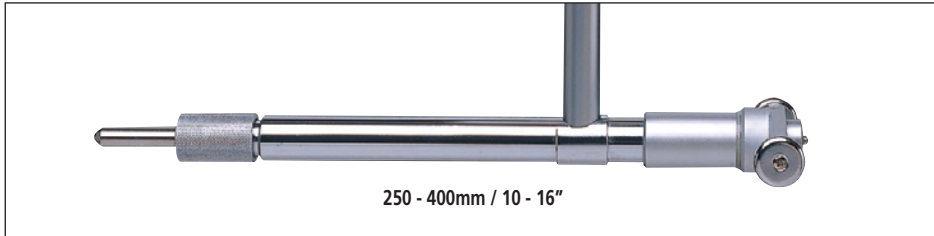
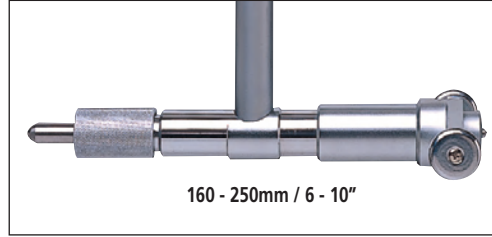
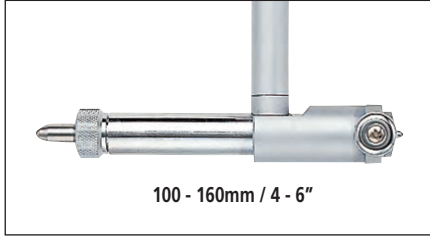
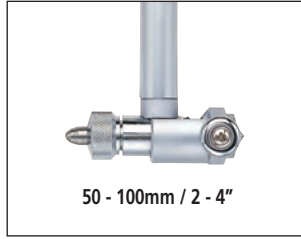
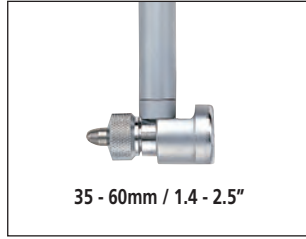
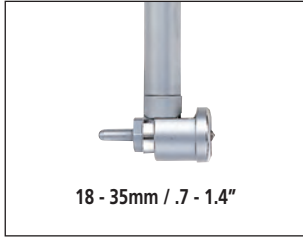

## DIMENSIONS

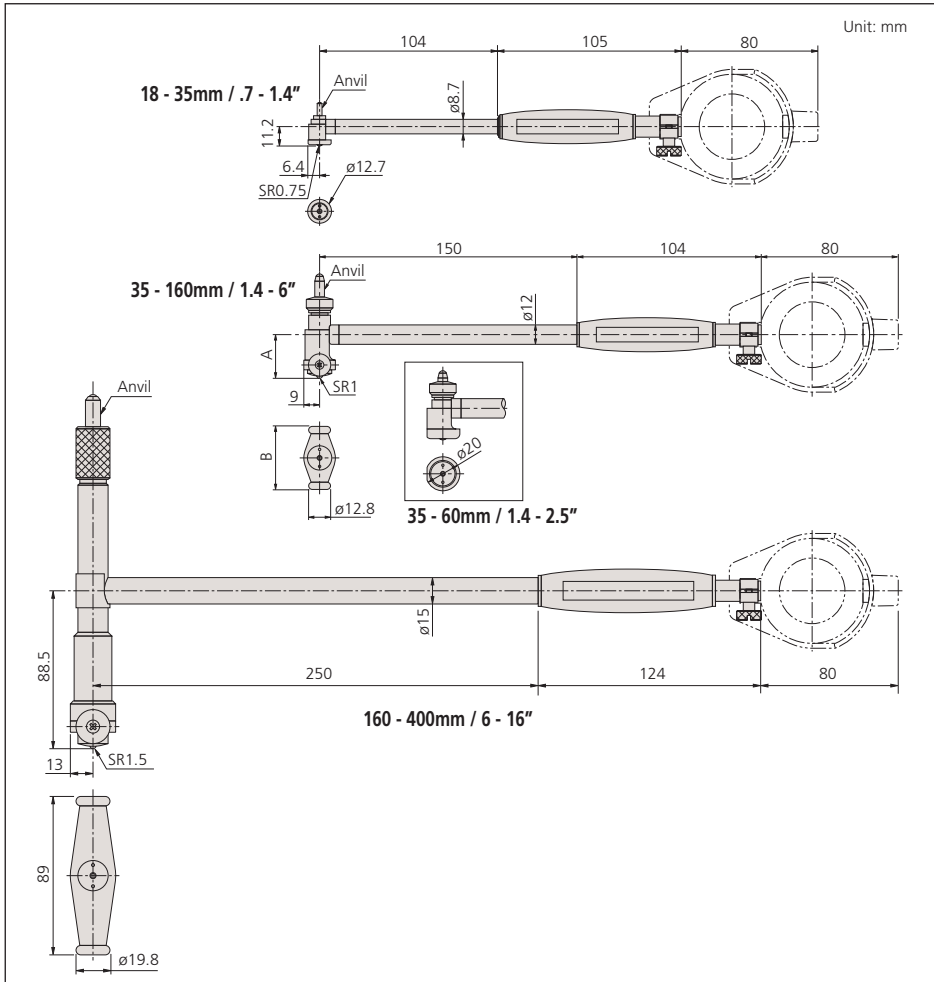

## Optional Accessories

- 953549:** 125mm / 4.92" Extension rod for 18-35mm / .7 - 1.4" models
- 953552:** 125mm / 4.92" Extension rod for 35-160mm / 1.4 - 6.5" models
- 953557:** 125mm / 4.92" Extension rod for 160-400mm / 6.5 - 16" models
- 953550:** 250mm / 9.84" Extension rod for 18-35mm / .7 - 1.4" models
- 953553:** 250mm / 9.84" Extension rod for 35-160mm / 1.4 - 6.5" models
- 952361:** 250mm / 9.84" Extension rod for 160-400mm / 6.5 - 16" models
- 953551:** 500mm / 19.69" Extension rod for 18-35mm / .7 - 1.4" models
- 953554:** 500mm / 19.69" Extension rod for 35-160mm / 1.4 - 6.5" models
- 953558:** 500mm / 19.69" Extension rod for 160-400mm / 6.5 - 16" models
- 953555:** 750mm / 29.53" Extension rod for 35-160mm / 1.4 - 6.5" models
- 953559:** 750mm / 29.53" Extension rod for 160-400mm / 6.5 - 16" models
- 953556:** 1000mm / 39.37" Extension rod for 35-160mm / 1.4 - 6.5" models
- 953560:** 1000mm / 39.37" Extension rod for 160-400mm / 6.5 - 16" models

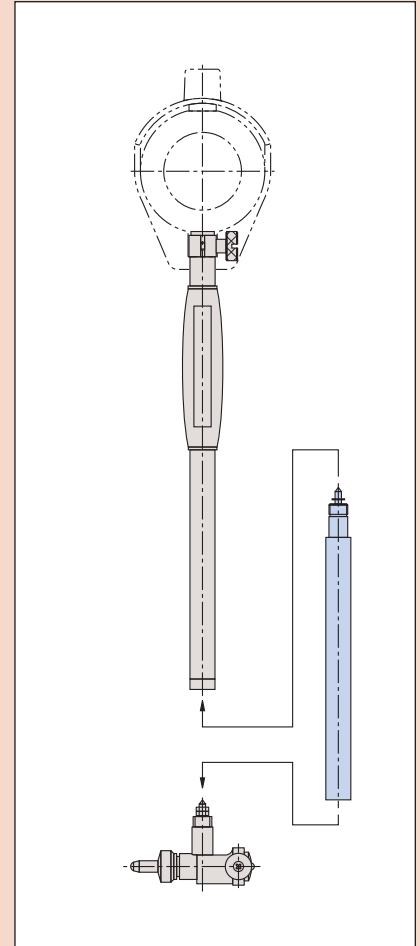

Setting ring (See page C-30.)



511-786

### Technical Data

Accuracy:  $2\mu\text{m} / .00008''$   
 Indication stability:  $1\mu\text{m} / .00004''$   
 Graduation: 0.01mm, 0.001mm, .0005" or .0001"

### Contact Point

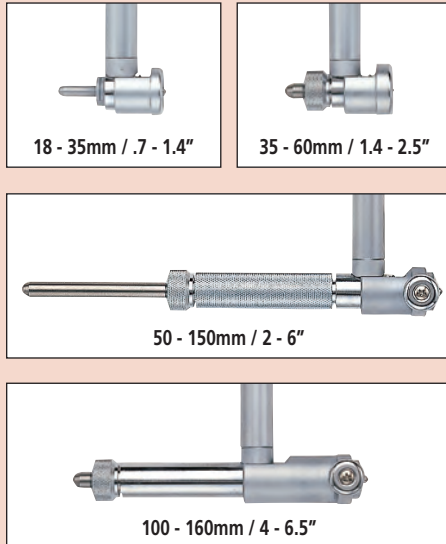

### Optional Accessories

---- : Setting ring (See page C-30.)

# Bore Gages

## SERIES 511 — Short Leg Type

### FEATURES

- Compact and lightweight because of the short length below the grip.
- Carbide-tipped contact point for durability.

### SPECIFICATIONS

Inch		Gage Stem $\phi 3/8''$		
Measuring Range	Order No. With 2922SB Graduation .0005"	Order No. With 2923SB-10 Graduation .0001"	Number of Anvils	Number of Spacers
.7 - 1.4"	511-786	511-791	9	2
1.4 - 2.5"	511-787	511-792	6	4
2.0 - 6.0"	511-788	511-793	11 (2" sub anvil)	4
4.0 - 6.5"	511-789	511-794	13	4

Metric		Gage Stem $\phi 8\text{mm}$		
Measuring Range	Order No. With 2046SB Graduation 0.01mm	Order No. With 2109SB-10 Graduation 0.001mm	Number of Anvils	Number of Spacers
18 - 35mm	511-766	511-771	9	2
35 - 60mm	511-767	511-772	6	4
50 - 150mm	511-768	511-773	11 (50mm Sub Anvil)	4
100 - 160mm	511-769	511-774	13	4

### DIMENSIONS

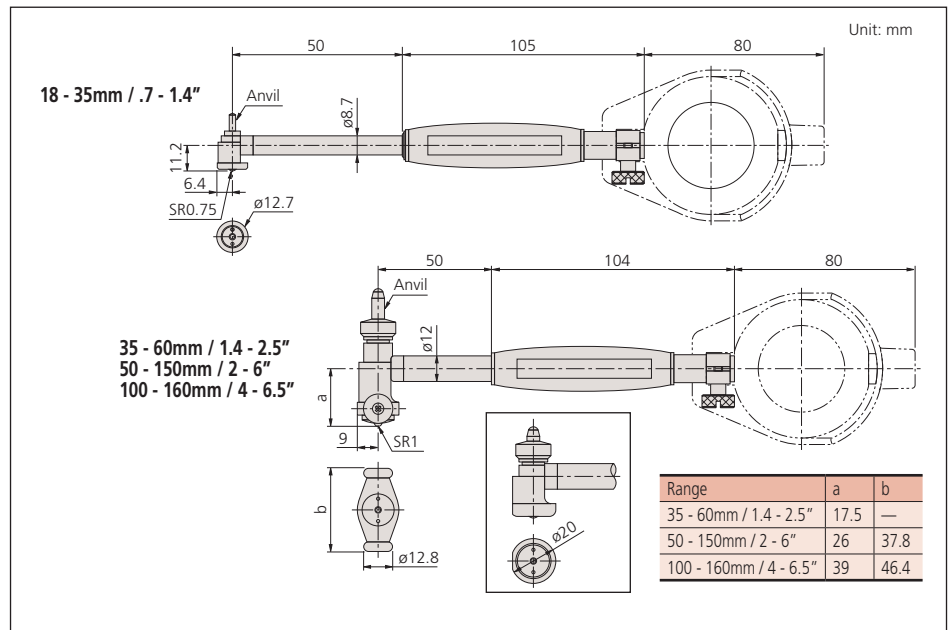

# Bore Gages

## SERIES 511 — for Blind Holes

### FEATURES

- Can measure ID at position close to the bottom of blind holes.

### SPECIFICATIONS

**Metric** Gage Stem  $\varnothing$  8mm

Measuring Range	Order No. Without Dial Gage	Order No. With 2046SB Graduation 0.01mm	Order No. With 2019SB-10 Graduation 0.001mm	Number of Anvils	Number of Spacers
15 - 35mm	511-401*	511-411	511-421	11 10mm Sub-Anvil	1
35 - 60mm	511-402*	511-412	511-422	6	4
50 - 100mm	511-403*	511-413	511-423	11	4
50 - 150mm	511-404*	511-414	511-424	11 50mm Sub-Anvil	4

\*Does not come supplied with Dial Gage Protector Cover (21DZA000)

**Inch** Gage Stem Dia. .375"

Measuring Range	Order No. Without Dial Gage	Order No. With 2922SB Graduation .0005"	Order No. With 2923SB-10 Graduation .0001"	Number of Anvils	Number of Spacers
.6 - 1.4"	511-406*	511-431	511-441	11 .4" Sub-Anvil	1
1.4 - 2.4"	511-407*	511-432	511-442	6	4
2 - 4"	511-408*	511-433	511-443	11	4
2 - 6"	511-409*	511-434	511-444	11 2" Sub-Anvil	4

\*Does not come supplied with Dial Gage Protector Cover (21DZA000)

### DIMENSIONS

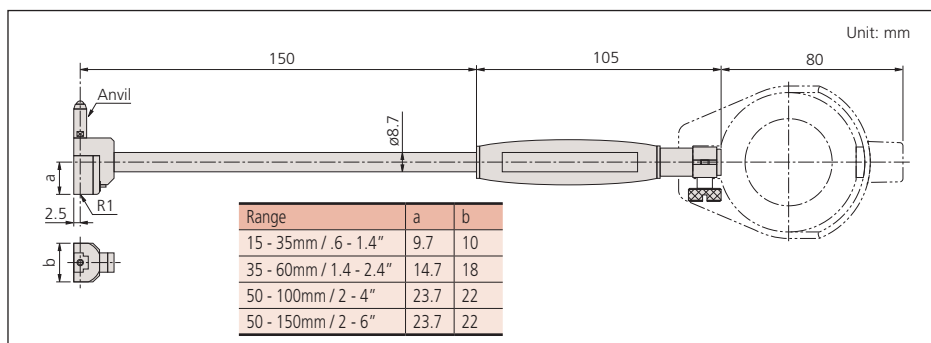

511-412

### Technical Data

Accuracy:  $5\mu\text{m} / .0002''$   
 Indication stability:  $2\mu\text{m} / .00008''$   
 Graduation: 0.01mm, 0.001mm, .0005" or .0001"

### Contact Point

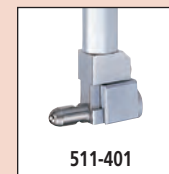

511-401

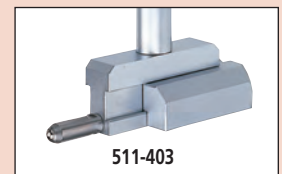

511-403

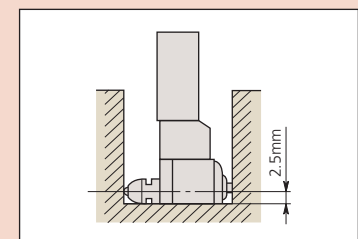

### Optional Accessories

----- : Setting ring (See page C-30.)  
 Extension Rods are not available for these models





511-843

# Bore Gages

## SERIES 511 — with Micrometer Head

### FEATURES

- Interchangeable anvil is attached to a micrometer head for accurate dimensional setting.
- Wide measuring range with sub-anvils.
- Carbide ball contact point for durability.
- Extension rods (optional) can be attached for measuring deep holes.
- Optional Setting Rings offer the best method of zero-setting Bore Gages.

### SPECIFICATIONS

**Inch** Gage Stem  $\varnothing$  3/8"

Measuring Range	Order No. Without Indicator	Order No. With 2922SB Graduation .0005"	Order No. With 2923SB-10 Graduation .0001"	Mic Head Travel	Sub Anvil
2.4 - 4.0"	511-833*	511-843	511-853	.4"	.4", .8"
4.0 - 6.4"	511-834*	511-844	511-854	.5"	.4", .8", .8"
6.0 - 10"	511-835*	511-845	511-855	.5"	.4", .8", .8", 2"
10 - 16"	511-836*	511-846	511-856	1"	1", 2", 2"
16 - 24"	511-837*	511-847	511-857	2"	2", 4"
24 - 32"	511-838*	511-848	511-858	2"	2", 4"

\*Does not come supplied with Dial Gage Protector Cover (21DZA000)

### Technical Data

Accuracy:  $2\mu\text{m}$  / .00008"  
 Indication stability:  $1\mu\text{m}$  / .00004"  
 Graduation: 0.01mm, 0.001mm, .0005" or .0001"

### Optional Accessories

- 953549:** 125mm / 4.92" Extension rod for 18-35mm / .7 - 1.4" models
- 953552:** 125mm / 4.92" Extension rod for 35-160mm / 1.4 - 6.5" models
- 953557:** 125mm / 4.92" Extension rod for 160-400mm / 6.5 - 16" models
- 953550:** 250mm / 9.84" Extension rod for 18-35mm / .7 - 1.4" models
- 953553:** 250mm / 9.84" Extension rod for 35-160mm / 1.4 - 6.5" models
- 952361:** 250mm / 9.84" Extension rod for 160-400mm / 6.5 - 16" models
- 953551:** 500mm / 19.69" Extension rod for 18-35mm / .7 - 1.4" models
- 953554:** 500mm / 19.69" Extension rod for 35-160mm / 1.4 - 6.5" models
- 953558:** 500mm / 19.69" Extension rod for 160-400mm / 6.5 - 16" models
- 953555:** 750mm / 29.53" Extension rod for 35-160mm / 1.4 - 6.5" models
- 953559:** 750mm / 29.53" Extension rod for 160-400mm / 6.5 - 16" models
- 953556:** 1000mm / 39.37" Extension rod for 35-160mm / 1.4 - 6.5" models
- 953560:** 1000mm / 39.37" Extension rod for 160-400mm / 6.5 - 16" models

**Metric** Gage Stem  $\varnothing$  8mm

Measuring Range	Order No. Without Indicator	Order No. With 2046SB Graduation 0.01mm	Order No. With 2109SB-10 Graduation 0.001mm	Mic Head Travel	Sub Anvil
60 - 100mm	511-803*	511-813	511-823	10mm	10mm, 20mm
100 - 160mm	511-804*	511-814	511-824	13mm	10mm, 20mm, 20mm
150 - 250mm	511-805*	511-815	511-825	13mm	10mm, 20mm, 20mm, 50mm
250 - 400mm	511-806*	511-816	511-826	25mm	25mm, 50mm, 50mm
400 - 600mm	511-807*	511-817	511-827	50mm	50mm, 100mm
600 - 800mm	511-808*	511-818	511-828	50mm	50mm, 100mm

\*Does not come supplied with Dial Gage Protector Cover (21DZA000)

## Contact Point

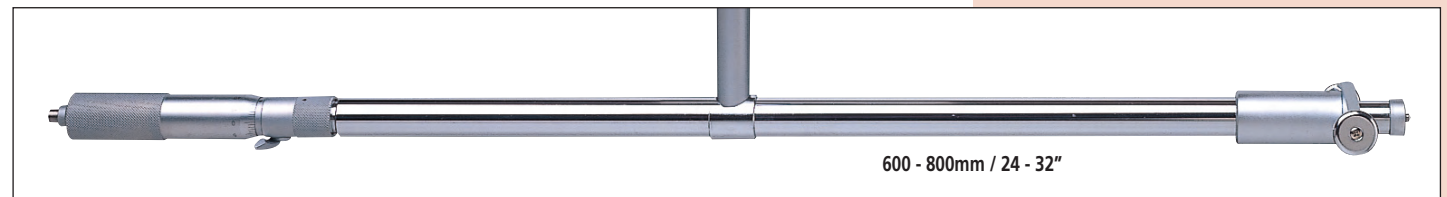
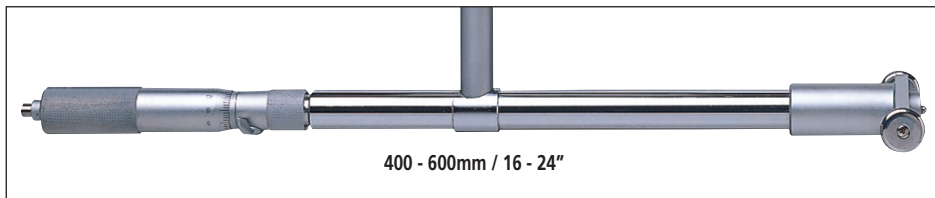
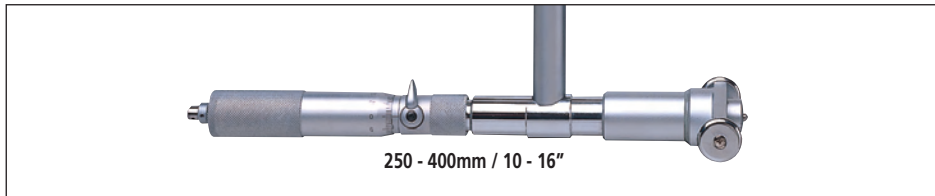
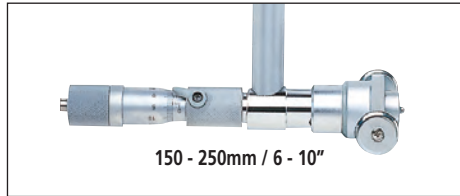
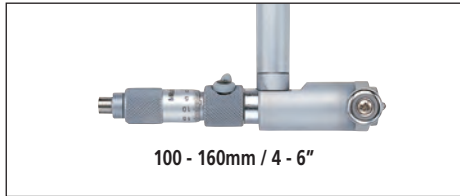
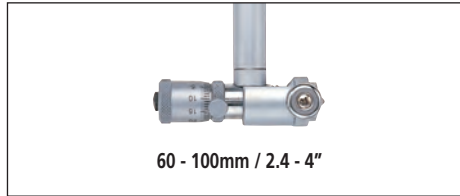
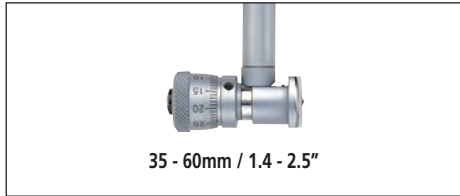

## DIMENSIONS

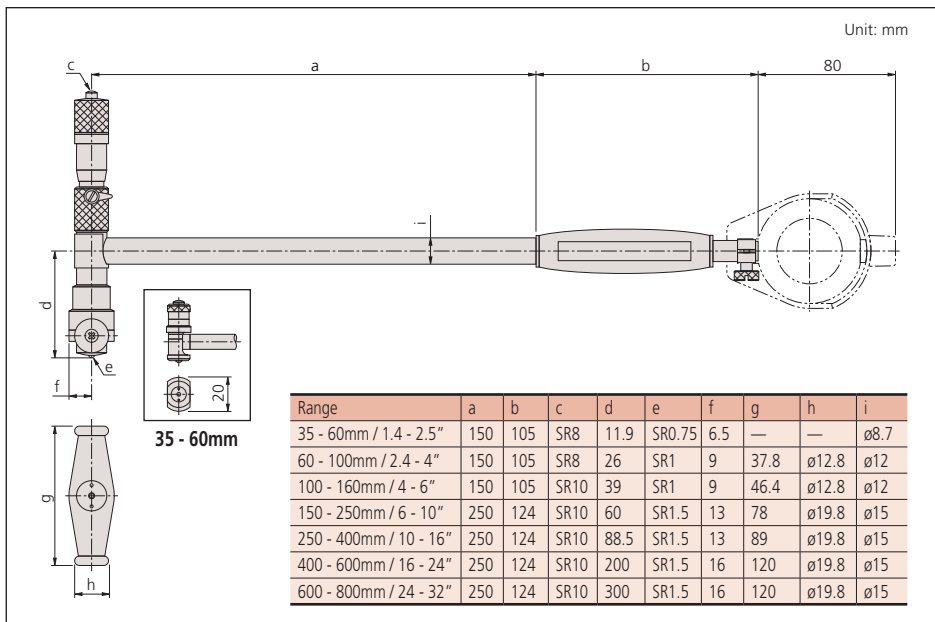



**SPC**

**ABSOLUTE®**  
Absolute System Patented by MITUTOYO

**Technical Data**

Accuracy: Wide Range: 0.003mm / .00012"  
Narrow Range: 0.002mm / .00008"  
Resolution: .00005" / 0.001mm  
Display: LCD  
Battery: SR44 (1 pc.) (938882)  
Battery life: Approx. 9 months for normal use  
Dust/Water protection level: Conforming to IP53

**Functions**

Origin-set, Zero-Setting, Presetting, Power on/off, inch/mm conversion (inch/mm type only), Data output, GO/±NG tolerance judgment  
Alarm: Low battery voltage, scale contamination, over-flow error, tolerance limit setting error

**Optional Accessories**

**21DZA089:** Extension rod 250 mm (10")  
**21DZA081:** Extension rod 500 mm (20")  
**516-118-10:** Origin setup metric rectangular gage block set  
**516-119-10:** Origin setup metric square gage block set  
**516-120-26:** GB calibration kit for series 511 bore gage. (9 pcs GB and plain jaw, 160mm holder)  
**905338:** SPC cable (40" / 1m)  
**905409:** SPC cable (80" / 2m)  
----- : Setting ring (See page C-30.)



Origin setup gage block set

Example: using four extension rods.

# ABSOLUTE Digimatic Bore Gage

## SERIES 511

This ABSOLUTE Digimatic bore gage is exclusively designed for ID measurement.



511-521

**FEATURES**

- The minimum value holding function provides the easy detection of hole diameter.



- Up to three sets of master value and upper/lower tolerance value can be memorized.
- An analog bar indicator is integrated to enhance the intuition in reading.
- GO/±NG judgment is performed by setting the upper and lower tolerances.
- Up to four rods (250mm or 500mm) can be used.

**SPECIFICATIONS**

Inch/Metric		
Range	Order No.	Probe depth
1.8 - 4" / 45 - 100mm	511-521	6" (152.4mm)
4 - 6.5" / 100 - 160mm	511-522	6" (152.4mm)

**DIMENSIONS AND MASS**

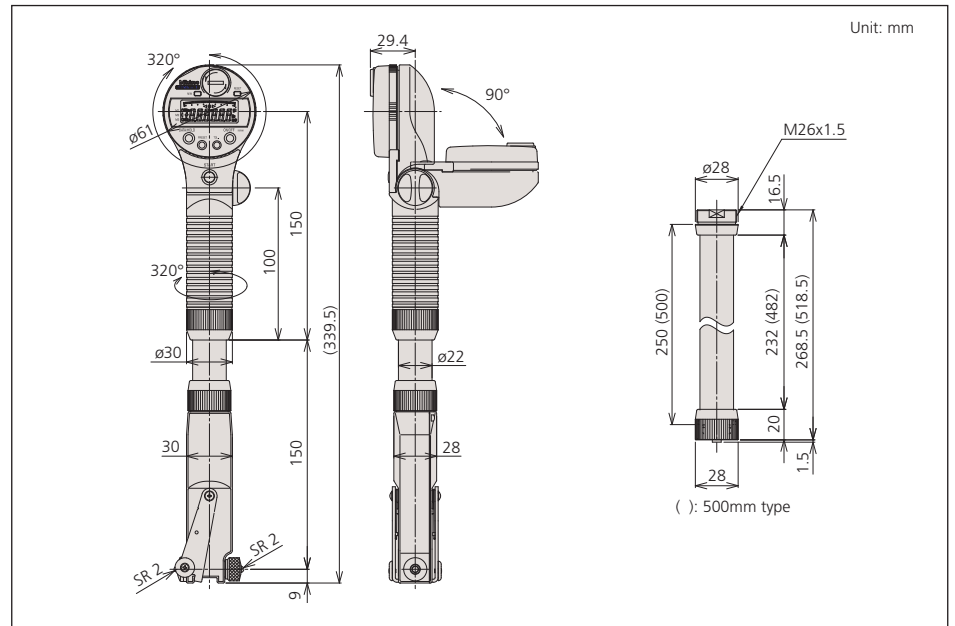

MASS: 500g

**Mitutoyo**

# Bore Gages

## SERIES 526 — for Extra Small Holes

These Bore Gages measure diameters of small holes. The radial displacement of split-ball contact is converted to axial displacement of measuring rod, which is shown on the dial indicator.

### FEATURES

- Optional stand (215-120M) is available for efficient measurement of multiple small holes.

### SPECIFICATIONS

**Metric** Gage Stem  $\varnothing$  8mm

Measuring Range	Order No. Without Dial Gage	Order No. With 2046SB Graduation 0.01mm	Order No. With 2019SB-10 Graduation 0.001mm	Number of Anvils	Number of Needles	Probe depth (D)
0.95 - 1.55mm	526-170*	526-173	526-172	6	1	11.5mm
1.5 - 4mm	526-160*	526-163	526-162	9	2	17.5, 22.5mm
3.7 - 7.3mm	526-150*	526-153	526-152	7	1	32mm
7 - 10mm	—	526-126	526-124	6	1	56mm
10 - 18mm	—	526-127	526-125	8	1	62mm

\*Does not come supplied with Dial Gage Protector (21DZA000)

**Inch** Gage Stem Dia .375"

Measuring Range	Order No. Without Dial Gage	Order No. With 2922SB Graduation .0005"	Order No. With 2923SB-10 Graduation .0001"	Number of Anvils	Number of Needles	Probe depth (D)
.037 - .061"	526-175*	—	526-176	5	1	.45"
.06 - .157"	526-165*	—	526-166	9	2	.68", .89"
.145 - .29"	526-155*	—	526-156	7	1	1.26"
.3 - .4"	526-103*	526-119	526-122	6	1	2.2"
.4 - .7"	526-104*	526-120	526-123	8	1	2.4"

\*Does not come supplied with Dial Gage Protector (21DZA000)

### DIMENSIONS

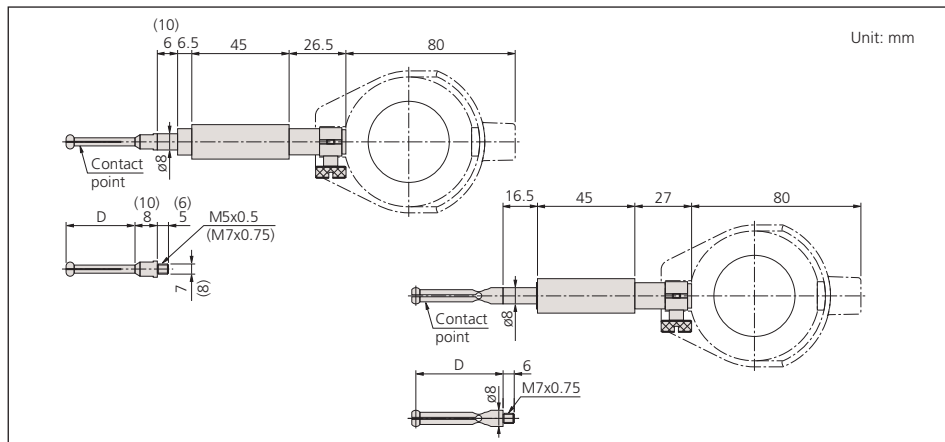

### DIAL FACES

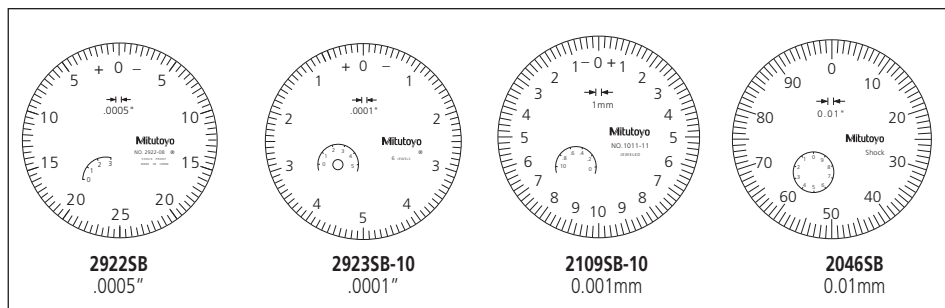

526-172

526-127

### Technical Data

Accuracy:  $4\mu\text{m} / .00016"$   
 Indication stability:  $2\mu\text{m} / .00008"$   
 Graduation: 0.01mm, 0.001mm, .0005" or .00001"

### Contact Point

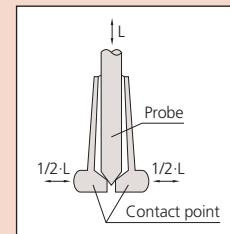

### Optional Accessory

215-120-10: Bore gage stand



----- : Setting ring (See page C-30.)

# Digimatic Chamfer Chek

**SERIES 547 - I.D. Measures the top diameter of tapered holes and chamfers O.D. measures the minor end diameter of tapered conical parts**

## Standard Accessories

- 64AAA012: Master Plate 3"(W) x 2"(D) x .925"(H)
- 21BZA778: Black Leather Case 9.7"(W) x 2"(D) x 6.1"(H)
- 21BZA779\*: Wooden box 12.8"(W) x 5.1"(D) x 3.63"(H)  
\* 547-481 (DCI-2090) only

## Optional Accessories

### Setting Master

Order No.	Model No.	Diameter	Accuracy
<b>Chamfer Chek I.D.</b>			
64AAA007	SM-1000	*.375" / .750" (I.D.)	±.0002"
64AAA008	SM-2000	*1.25" / 1.75" (I.D.)	±.0003"
64AAA133		9.525mm (I.D.)	±0.005mm
64AAA134		19.05mm (I.D.)	±0.008mm
<b>Chamfer Chek O.D.</b>			
64AAA009	SM-1000E	*.375" / .750" (O.D.)	±.0002"

- 905338: SPC cable (40" / 1m)
- 905409: SPC cable (80" / 2m)



547-480

547-482

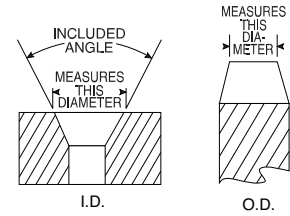

547-480 Shown with optional setting master.

## SPECIFICATIONS

### Inch / Metric

Resolution	Diameter Range	Order No.	Model No.	Accuracy	Mass
<b>Chamfer Chek I.D.</b>					
.0005"/0.01mm	.02-1" / 0.5-25.4mm	547-480	DCI-1090	±.001" / ±0.025mm	1.75lbs./793g
.0005"/0.01mm	1-2" / 25.4-50.8mm	547-481	DCI-2090	±.001" / ±0.025mm	3.97lbs./1,800g
<b>Chamfer Chek O.D.</b>					
.0005"/0.01mm	1/8"-1/2" / 3.18-12.7mm	547-482	DCO-0590	±.001" / ±0.025mm	1.75lbs./793g
.0005"/0.01mm	3/8"-1" / 9.52-25.4mm	547-483	DCO-1090	±.001" / ±0.025mm	1.75lbs./793g



526-007M-10

MEASURES THIS DIAMETER



# Digimatic Hole Chek

**SERIES 526 - Instant diameter measurement of small holes**

## SPECIFICATIONS

### Inch / Metric

Resolution	Diameter Range	Order No.	Model No.	Accuracy	Mass
.0005"/0.01mm	.010" - .330"	526-007M-10	DHC-0133	±.001" / ±0.025mm	1.5lbs./680g

## Optional Accessories

### Setting Master

Order No.	Model No.	Diameter	Accuracy
64AAA003	SM-040	.029"	±.0002"
64AAA004	SM-130	.078"	±.0002"
64AAA005	SM-230	.178"	±.0002"
64AAA006	SM-330	.278"	±.0002"

## Standard Accessories

- 21BZA778: Black Leather Case 9.7"(W) x 2"(D) x 6.1"(H)



# Setting Ring

## SERIES 177 — Accessories for Inside Micrometers, Holtest and Dial Bore Gages

### FEATURES

- Used for quick and accurate setting of dial bore gages, Holtest, and inside micrometers.
- If a setting ring of an optimal size is prepared, it can be used for calibration.

### Steel Setting Rings



### Ceramic Setting Rings



### How to read the indicated value

Series 526

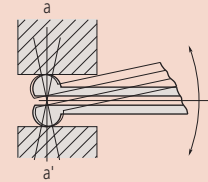

The 526 series has a gage head with high curvature. Alignment with the diameter (a-a') is achieved by rotating the gage head in the direction indicated by the arrow, and the reading is the maximum value read from the dial indicator.

Series 511

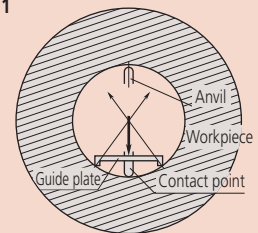

The 511 series provides a guide plate to align the setting ring diameter with the measurement axis of the bore gage.

### DIMENSIONS

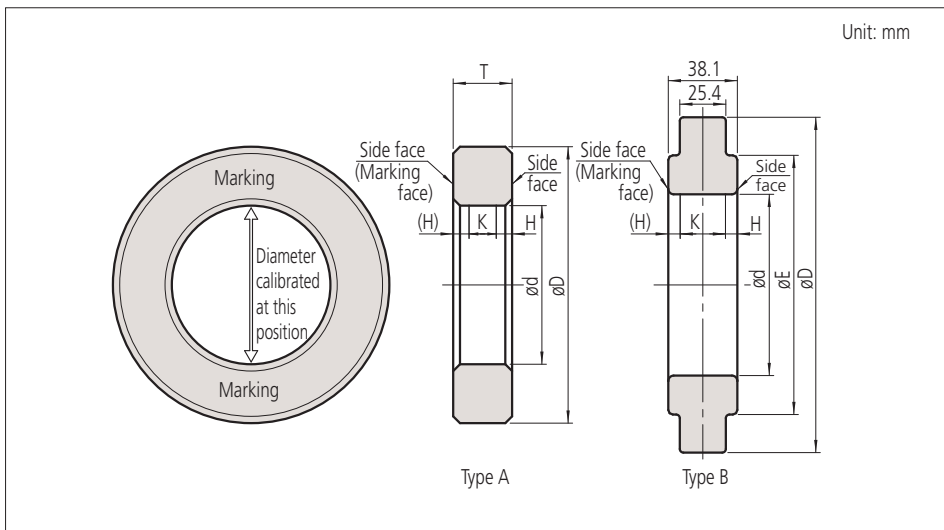

# SPECIFICATIONS

## Steel Setting Rings

Order No.	Nominal size $\phi D$	Dimensions (mm)			Type	Accuracy				
		$\phi D$	$\phi E$	T		Tolerance between the nominal size and the actual diameter ( $\mu m$ )	Uncertainty of marked diameter value ( $\mu m$ )*1	Roundness/Cylindricity ( $\mu m$ )*2	Distance from the side face H (mm)	Size of warranted calibration surface K (mm)
177-220	1mm	20	—	4	A	$\pm 10$	$\pm 1.5$	1	1.6	0.8
177-222	1.1mm	20	—	4	A	$\pm 10$	$\pm 1.5$	1	1.6	0.8
177-225	1.2mm	20	—	4	A	$\pm 10$	$\pm 1.5$	1	1.6	0.8
177-227	1.3mm	20	—	4	A	$\pm 10$	$\pm 1.5$	1	1.6	0.8
177-230	1.4mm	20	—	4	A	$\pm 10$	$\pm 1.5$	1	1.6	0.8
177-236	1.75mm	25	—	5	A	$\pm 10$	$\pm 1.5$	1	1.6	1.8
177-239	2mm	25	—	5	A	$\pm 10$	$\pm 1.5$	1	1.6	1.8
177-242	2.25mm	25	—	5	A	$\pm 10$	$\pm 1.5$	1	1.6	1.8
177-208	2.5mm	25	—	7	A	$\pm 10$	$\pm 1.5$	1	1.7	3.6
177-246	2.75mm	25	—	7	A	$\pm 10$	$\pm 1.5$	1	1.7	3.6
177-248	3mm	25	—	7	A	$\pm 10$	$\pm 1.5$	1	1.7	3.6
177-250	3.25mm	25	—	7	A	$\pm 10$	$\pm 1.5$	1	1.7	3.6
177-252	3.5mm	25	—	7	A	$\pm 10$	$\pm 1.5$	1	1.7	3.6
177-255	3.75mm	25	—	7	A	$\pm 10$	$\pm 1.5$	1	1.7	3.6
177-204	4mm	25	—	7	A	$\pm 10$	$\pm 1.5$	1	1.7	3.6
177-257	4.5mm	25	—	7	A	$\pm 10$	$\pm 1.5$	1	1.7	3.6
177-205	5mm	25	—	7	A	$\pm 10$	$\pm 1.5$	1	1.7	3.6
177-263	5.5mm	25	—	7	A	$\pm 10$	$\pm 1.5$	1	1.7	3.6
177-267	6mm	25	—	7	A	$\pm 10$	$\pm 1.5$	1	1.7	3.6
177-271	6.5mm	25	—	7	A	$\pm 10$	$\pm 1.5$	1	1.7	3.6
177-275	7mm	25	—	7	A	$\pm 10$	$\pm 1.5$	1	1.7	3.6
177-125	8mm	32	—	10	A	$\pm 10$	$\pm 1.5$	1	2.0	6.0
177-279	9mm	32	—	10	A	$\pm 10$	$\pm 1.5$	1	2.0	6.0
177-126	10mm	32	—	10	A	$\pm 10$	$\pm 1.5$	1	2.0	6.0
177-284	12mm	32	—	10	A	$\pm 10$	$\pm 1.5$	1	2.0	6.0
177-132	14mm	38	—	10	A	$\pm 10$	$\pm 1.5$	1	2.0	6.0

Order No.	Nominal size $\phi D$	Dimensions (mm)			Type	Accuracy				
		$\phi D$	$\phi E$	T		Tolerance between the nominal size and the actual diameter ( $\mu m$ )	Uncertainty of marked diameter value ( $\mu m$ )*1	Roundness/Cylindricity ( $\mu m$ )*2	Distance from the side face H (mm)	Size of warranted calibration surface K (mm)
177-177	16mm	45	—	10	A	$\pm 10$	$\pm 1.5$	1	2.0	6.0
177-133	17mm	45	—	10	A	$\pm 10$	$\pm 1.5$	1	2.0	6.0
177-285	18mm	45	—	10	A	$\pm 10$	$\pm 1.5$	1	2.0	6.0
177-286	20mm	45	—	10	A	$\pm 10$	$\pm 1.5$	1	2.0	6.0
177-139	25mm	53	—	15	A	$\pm 10$	$\pm 1.5$	1	3.2	8.6
177-288	30mm	71	—	15	A	$\pm 10$	$\pm 1.5$	1	3.2	8.6
177-140	35mm	71	—	15	A	$\pm 10$	$\pm 1.5$	1	3.2	8.6
177-290	40mm	71	—	15	A	$\pm 10$	$\pm 1.5$	1	3.2	8.6
177-178	45mm	85	—	15	A	$\pm 10$	$\pm 1.5$	1	3.7	7.6
177-146	50mm	85	—	20	A	$\pm 20$	$\pm 1.5$	1	3.7	12.6
177-292	60mm	112	—	20	A	$\pm 20$	$\pm 1.5$	1	3.7	12.6
177-314	62mm	112	—	20	A	$\pm 20$	$\pm 1.5$	1.5	3.7	12.6
177-147	70mm	112	—	20	A	$\pm 20$	$\pm 1.5$	1.5	3.7	12.6
177-316	75mm	125	—	25	A	$\pm 20$	$\pm 1.5$	1.5	4.2	16.6
177-294	80mm	125	—	25	A	$\pm 20$	$\pm 1.5$	1.5	4.2	16.6
177-318	87mm	140	—	25	A	$\pm 20$	$\pm 1.5$	1.5	4.2	16.6
177-148	90mm	140	—	25	A	$\pm 20$	$\pm 1.5$	1.5	4.2	16.6
177-296	100mm	160	—	25	A	$\pm 20$	$\pm 1.5$	2	4.2	16.6
177-298	125mm	210	168		B	$\pm 20$	$\pm 2.5$	2	5.3	27.5
177-300	150mm	235	187		B	$\pm 20$	$\pm 2.5$	2	5.3	27.5
177-302	175mm	260	215		B	$\pm 20$	$\pm 2.5$	2.5	5.3	27.5
177-304	200mm	311	244		B	$\pm 20$	$\pm 2.5$	2.5	5.3	27.5
177-306	225mm	337	264		B	$\pm 20$	$\pm 2.5$	2.5	5.3	27.5
177-308	250mm	362	290		B	$\pm 20$	$\pm 2.5$	3	5.3	27.5
177-310	275mm	413	321		B	$\pm 20$	$\pm 2.5$	3	5.3	27.5
177-312	300mm	438	340		B	$\pm 20$	$\pm 2.5$	3	5.3	27.5

Order No.	Nominal size $\phi D$	Dimensions (mm)			Type	Accuracy				
		$\phi D$	$\phi E$	T		Tolerance between the nominal size and the actual diameter (inch)	Uncertainty of marked diameter value (inch)*1	Roundness/Cylindricity (inch)*2	Distance from the side face H (mm)	Size of warranted calibration surface K (mm)
177-209	.1"	25	—	7	A	$\pm .0004$ "	$\pm .00006$ "	.00004"	1.5	4.0
177-206	.16"	25	—	7	A	$\pm .0004$ "	$\pm .00006$ "	.00004"	1.5	4.0
177-207	.24"	25	—	7	A	$\pm .0004$ "	$\pm .00006$ "	.00004"	1.5	4.0
177-281	.275"	25	—	7	A	$\pm .0004$ "	$\pm .00006$ "	.00004"	1.8	3.4
177-179	.35"	32	—	10	A	$\pm .0004$ "	$\pm .00006$ "	.00004"	1.8	6.4
177-283	.425"	32	—	10	A	$\pm .0004$ "	$\pm .00006$ "	.00004"	1.8	6.4
177-180	.5"	32	—	10	A	$\pm .0004$ "	$\pm .00006$ "	.00004"	1.8	6.4
177-181	.6"	38	—	10	A	$\pm .0004$ "	$\pm .00006$ "	.00004"	1.8	6.4
177-182	.65"	45	—	10	A	$\pm .0004$ "	$\pm .00006$ "	.00004"	1.8	6.4
177-183	.7"	45	—	10	A	$\pm .0004$ "	$\pm .00006$ "	.00004"	1.8	6.4
177-287	.8"	45	—	10	A	$\pm .0004$ "	$\pm .00006$ "	.00004"	1.8	6.4
177-184	1"	53	—	15	A	$\pm .0004$ "	$\pm .00006$ "	.00004"	3.0	9.0
177-289	1.2"	71	—	15	A	$\pm .0004$ "	$\pm .00006$ "	.00004"	3.0	9.0
177-185	1.4"	71	—	15	A	$\pm .0004$ "	$\pm .00006$ "	.00004"	3.0	9.0
177-291	1.6"	71	—	15	A	$\pm .0004$ "	$\pm .00006$ "	.00004"	3.0	9.0
177-186	1.8"	85	—	15	A	$\pm .0004$ "	$\pm .00006$ "	.00004"	3.5	8.0

Order No.	Nominal size $\phi D$	Dimensions (mm)			Type	Accuracy				
		$\phi D$	$\phi E$	T		Tolerance between the nominal size and the actual diameter (inch)	Uncertainty of marked diameter value (inch)*1	Roundness/Cylindricity (inch)*2	Distance from the side face H (mm)	Size of warranted calibration surface K (mm)
177-187	2"	85	—	20	A	$\pm .0008$ "	$\pm .00006$ "	.00004"	3.5	13.0
177-293	2.4"	112	—	20	A	$\pm .0008$ "	$\pm .00006$ "	.00004"	3.5	13.0
177-315	2.5"	112	—	20	A	$\pm .0008$ "	$\pm .00006$ "	.00006"	4.0	12.0
177-188	2.8"	112	—	20	A	$\pm .0008$ "	$\pm .00006$ "	.00006"	4.0	12.0
177-317	3"	125	—	25	A	$\pm .0008$ "	$\pm .00006$ "	.00006"	4.0	17.0
177-295	3.2"	125	—	25	A	$\pm .0008$ "	$\pm .00006$ "	.00006"	4.0	17.0
177-319	3.5"	140	—	25	A	$\pm .0008$ "	$\pm .00006$ "	.00006"	4.0	17.0
177-189	3.6"	140	—	25	A	$\pm .0008$ "	$\pm .00006$ "	.00006"	4.0	17.0
177-297	4"	160	—	25	A	$\pm .0008$ "	$\pm .00006$ "	.00008"	4.0	17.0
177-299	5"	210	168	38.1	B	$\pm .0008$ "	$\pm .00010$ "	.00008"	5.0	28.1
177-301	6"	235	187	38.1	B	$\pm .0008$ "	$\pm .00010$ "	.00008"	5.0	28.1
177-303	7"	260	215	38.1	B	$\pm .0008$ "	$\pm .00010$ "	.00010"	5.0	28.1
177-305	8"	311	244	38.1	B	$\pm .0008$ "	$\pm .00010$ "	.00010"	5.0	28.1
177-307	9"	337	264	38.1	B	$\pm .0008$ "	$\pm .00010$ "	.00010"	5.0	28.1
177-309	10"	362	290	38.1	B	$\pm .0008$ "	$\pm .00010$ "	.00012"	5.0	28.1
177-311	11"	413	321	38.1	B	$\pm .0008$ "	$\pm .00010$ "	.00012"	5.0	28.1
177-313	12"	438	340	38.1	B	$\pm .0008$ "	$\pm .00010$ "	.00012"	5.0	28.1

## Cera Setting Rings

Order No.	Nominal size $\phi D$	Dimensions (mm)			Type	Accuracy				
		$\phi D$	$\phi E$	T		Tolerance between the nominal size and the actual diameter ( $\mu m$ )	Uncertainty of marked diameter value ( $\mu m$ )*1	Roundness/Cylindricity ( $\mu m$ )*2	Distance from the side face H (mm)	Size of warranted calibration surface K (mm)
177-418	4mm	25	—	7	A	$\pm 10$	$\pm 1.5$	1	1.7	3.6
177-420	6mm	25	—	7	A	$\pm 10$	$\pm 1.5$	1	1.7	3.6
177-423	8mm	32	—	10	A	$\pm 10$	$\pm 1.5$	1	2.0	6.0
177-424	10mm	32	—	10	A	$\pm 10$	$\pm 1.5$	1	2.0	6.0
177-425	12mm	32	—	10	A	$\pm 10$	$\pm 1.5$	1	2.0	6.0
177-427	16mm	45	—	10	A	$\pm 10$	$\pm 1.5$	1	2.0	6.0
177-429	20mm	45	—	10	A	$\pm 10$	$\pm 1.5$	1	2.0	6.0
177-430	25mm	53	—	15	A	$\pm 10$	$\pm 1.5$	1	3.2	8.6
177-431	30mm	71	—	15	A	$\pm 10$	$\pm 1.5$	1	3.2	8.6
177-432	35mm	71	—	15	A	$\pm 10$	$\pm 1.5$	1	3.2	8.6
177-433	40mm	71	—	15	A	$\pm 10$	$\pm 1.5$	1	3.2	8.6
177-434	45mm	85	—	15	A	$\pm 10$	$\pm 1.5$	1	3.2	8.6

Order No.	Nominal size $\phi D$	Dimensions (mm)			Type	Accuracy				
		$\phi D$	$\phi E$	T		Tolerance between the nominal size and the actual diameter (inch)	Uncertainty of marked diameter value (inch)*1	Roundness/Cylindricity (inch)*2	Distance from the side face H (mm)	Size of warranted calibration surface K (mm)
177-518	.16"	25	—	7	A	$\pm .0004$ "	$\pm .00006$ "	.00004"	1.5	4.0
177-520	.24"	25	—	7	A	$\pm .0004$ "	$\pm .00006$ "	.00004"	1.5	4.0
177-522	.275"	25	—	7	A	$\pm .0004$ "	$\pm .00006$ "	.00004"	1.5	4.0
177-523	.35"	32	—	10	A	$\pm .0004$ "	$\pm .00006$ "	.00004"	1.8	6.4
177-524	.425"	32	—	10	A	$\pm .0004$ "	$\pm .000$			

# RM-120 Ring Master

## Ring Gage Measuring Machine

### FEATURES

- The laser holoscale incorporated in the RM-120 eliminates the need for a reference gage block set and reference ring gages.
- Probe change is not required for the entire measuring range.
- Enhanced repeatability and lower measuring force achieved with the air bearing on the probe carriage guide.
- Workpiece alignment is easy to perform with the specially designed measuring table which is capable of moving, tilting, elevating, and 90 degree rotating.
- The model with an analog meter will further facilitate workpiece positioning.

### SPECIFICATIONS

Model No.	RM-120 with analog meter
Order No.	565-204A
Range	ID: .236 to 4.75" / 6 to 120mm
Resolution (Counter)	.0000001" / 0.0001mm
Analog meter	200µm / .007874", 20µm / .0007874"
Accuracy (±2σ)	±(0.3 + 5D/1000)µm D: Ring gage size diameter (mm)
Measuring unit	Laser Holoscale
Measuring force	Approx. 0.2N
Work piece size	OD: .7874 - 7.874" / 20 - 200mm Thickness: Up to 1.574" / 40mm
Air requirement	400KPa (58psi)
Air consumption	Approx. 30 liter per minute (12.8CFM)
Dimension (W x D x H)	720mm x 494mm x 875mm 28.35" x 19.45" x 34.45"
Mass	Approx. 260kg (573.2lbs)



This RM-120 conforms to the US CDRH regulations in 21 CFR 1040.

### Optional Accessories

- 02ASE690:** Master gage .250" with factory Inspection Certificate
- 02ASE700:** Master gage .500" with factory Inspection Certificate
- 02ASE710:** Master gage 3" with factory Inspection Certificate
- 02ASE720:** Master gage 4.750" with factory Inspection Certificate
- 02ASC530:** Master gage 6mm with factory Inspection Certificate
- 02ASC560:** Master gage 12.5mm with factory Inspection Certificate
- 02ASC580:** Master gage 75mm with factory Inspection Certificate
- 02ASC540:** Master gage 120mm with factory Inspection Certificate
- 02ASE480:** Vibration stand

# Bore Gage Zero Checker

## SERIES 515

The Bore Gage Zero Checker allows easy zero adjustment of dial bore gages with ranges of 18mm (.7") through 400mm (16") using gage blocks.

### SPECIFICATIONS

Order No.	Applicable range
515-590	18 -400mm (.7" - 16")

515-590

